

Setting the Standard for Automation™



Introdução à Norma ISA-101: Interfaces Homem-Máquina

Standards
Certification
Education & Training
Publishing
Conferences & Exhibits

ISA Distrito 4 - Grupo Standards

- A ISA - International Society of Automation (www.isa.org) é uma associação profissional sem fins lucrativos que estabelece normas e padrões para profissionais de engenharia e de tecnologia que trabalham para a melhoria de gestão, segurança operacionais e segurança cibernética de sistemas de controle e de automação usados na indústria e em infraestruturas críticas.
- Fundada em 1945, a ISA desenvolve normas amplamente utilizadas em todo o mundo; certifica profissionais da indústria; oferece treinamentos; publica livros e artigos técnicos; organiza conferências e exposições; e oferece programas de desenvolvimento de carreira e de networking para os seus 36.000 membros e 350.000 clientes ao redor do mundo.

Qual é o objetivo deste documento?



- O Grupo Standards da ISA Distrito 4 / Brasil é formado por profissionais de instrumentação e automação, especialistas em normas da ISA, que se reúnem para criar conteúdo local das normas para promover, divulgar e esclarecer dúvidas para os profissionais das indústrias no Brasil.
- Este documento oferece:
 - Principais pontos da norma ISA-101.1
 - Estudo sobre IHM´s de Alta Performance
 - Como aplicar a norma e exemplos

O que é a Norma ISA-101?



- Documento que reúne o conhecimento e experiência de profissionais ao redor do mundo que por diversos anos aplicaram as melhores práticas relacionadas as IHMs.
- A norma foi aprovada em 9 de Julho de 2015, com o objetivo de suportar todas as fases que compreendem o Ciclo de Vida da Interface Homem-Máquina para sistemas de automação de processos.
- A norma é homologada pelo ANSI – American National Standards Institute (www.ansi.org), órgão de regulamentação de normas dos Estados Unidos, por isso é referenciada por ANSI/ISA-101.01-2015

Como é estruturada a Norma ISA-101



- Apresenta o Ciclo de Vida do desenvolvimento de IHM's
- Modelo de Gestão
- Definição dos diversos atores
- Definição das necessidades de operação:
 - Detectar
 - Diagnosticar
 - Responder
 - Valorar
- Proposição de diversas formas de organização

Por que adotar a Norma ISA-101 em seu Sistema?



- Grande parte dos integradores possuem os modelos pré-definidos que usualmente não respeitam os limites sensoriais e cognitivos de seus usuários
- O desenvolvimento das aplicações utilizam a filosofia de “One-size-fits-all”
- A operação da IHM é muito mais que a simples representação do que ocorre em campo!
- A IHM não pode ser interpretada e desenvolvida como um videogame (o foco não é impressionar o usuário!)

Por que adotar a Norma ISA-101 em seu Sistema?



- A IHM esta inserida em um contexto operacional, portanto, não pode ser desenvolvida de forma isolada (exemplo: luminosidade, ruído, quantidade de operadores, aspectos ergonômicos e etc)
- A IHM, juntamente ao Sistema de Alarmes, pode se tornar mais uma camada de proteção e resposta às condições anormais do processo
- A IHM é o centro de informações e ponto de tomada de decisões, portanto, a gestão adequada é fundamental para garantir seu desempenho e confiabilidade
- A falta de fundamentação (base) permite que os usuários apliquem seus julgamentos ao sistema

Alguns Desafios em que a Norma ISA-101 pode lhe Ajudar...



- Distinguir o “Desejado” do “Apropriado” (quais os objetivos da IHM?)
- Resgatar condições operacionais que auxiliam no desempenho (Situation Awareness)
- Utilização de tecnologias COTS (Commercial Off the Shelf) e Arquiteturas Seguras
- Integração com demais sistemas



Status-at-a-Glance



IHM's de Alta Performance Visual

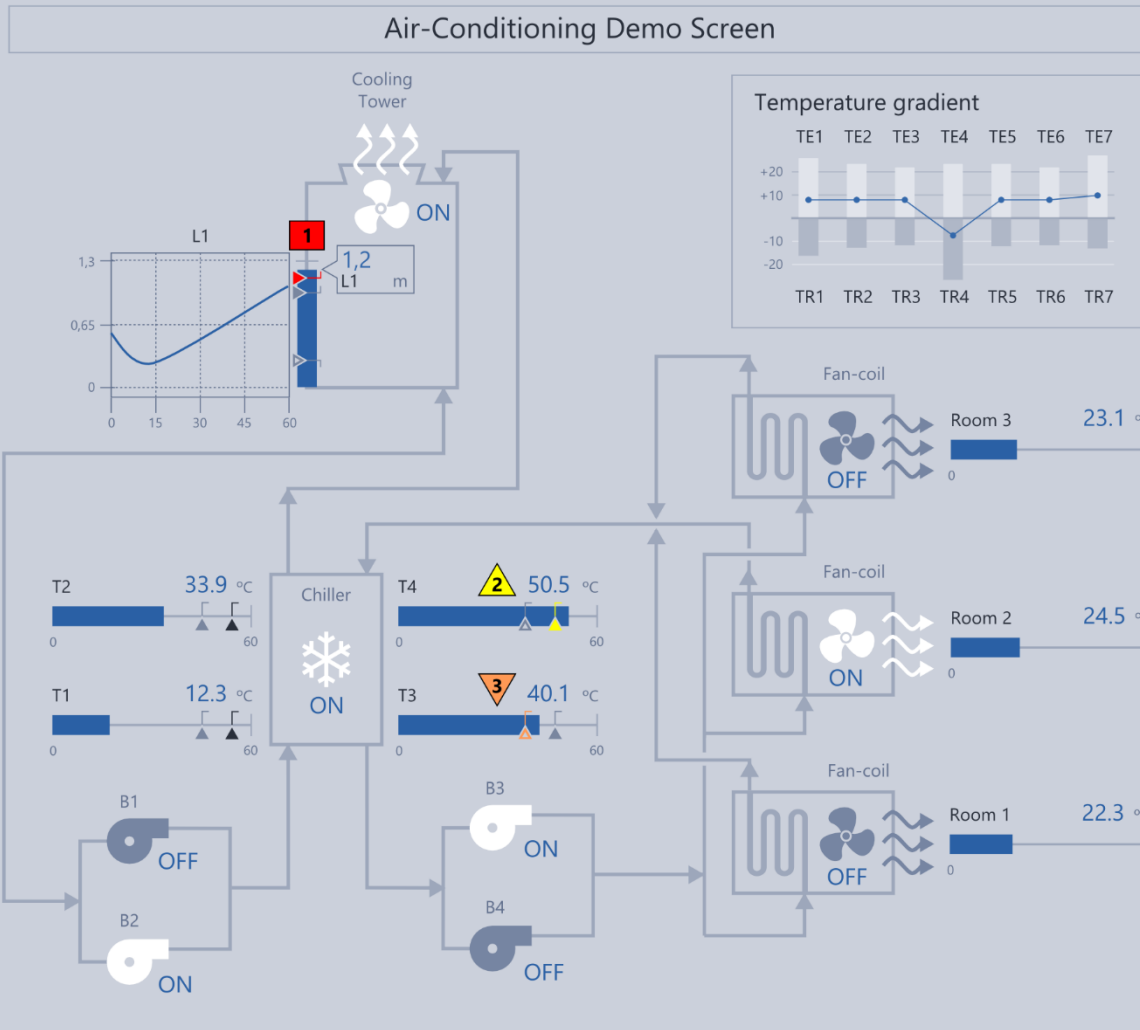

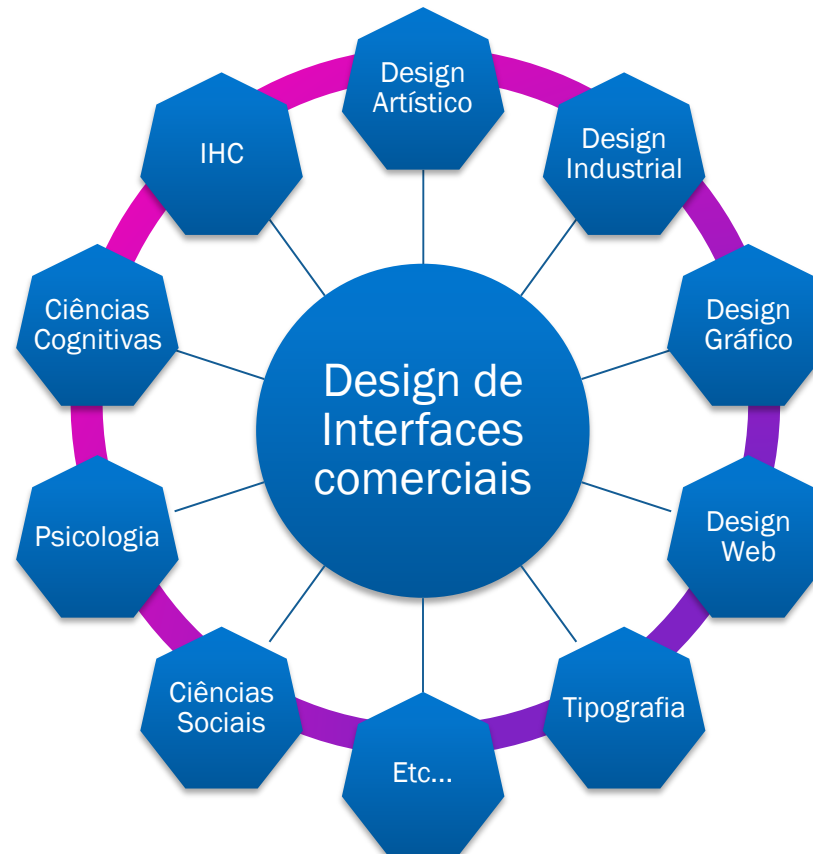

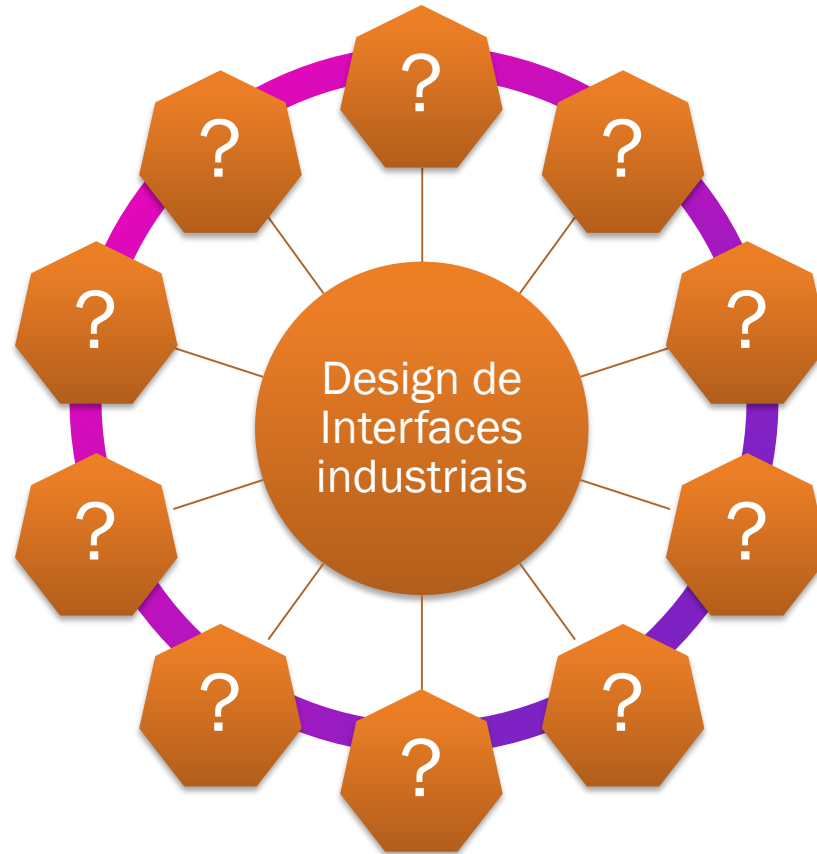

Ganhos reais



*Se você acha que
segurança custa caro,
experimente um acidente.*

Detecção de anormalidades antes da ocorrência de alarme

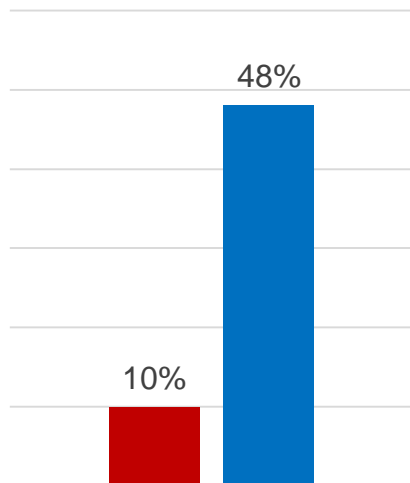

Sucesso ao lidar com situações anormais

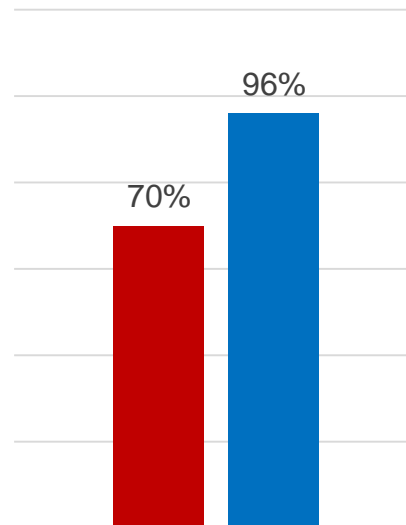

Tempo em minutos para completar tarefas em condição de anormalidade

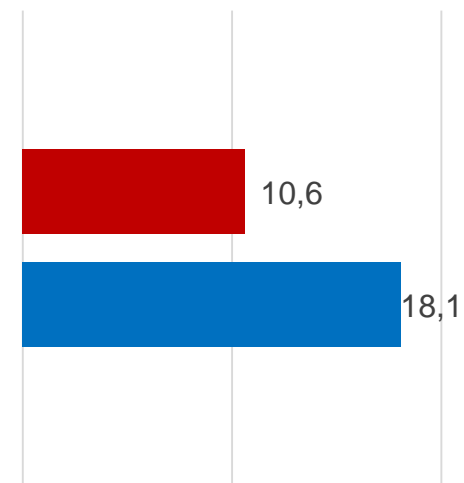

■ IHM Tradicional
■ IHM de Alto Desempenho

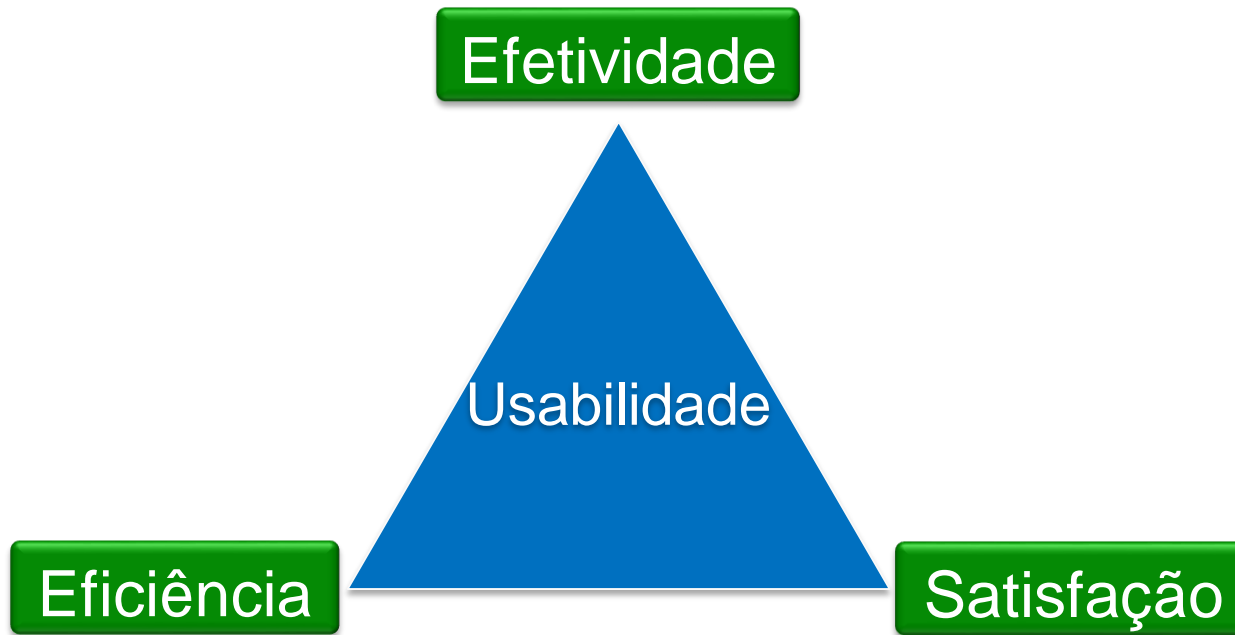

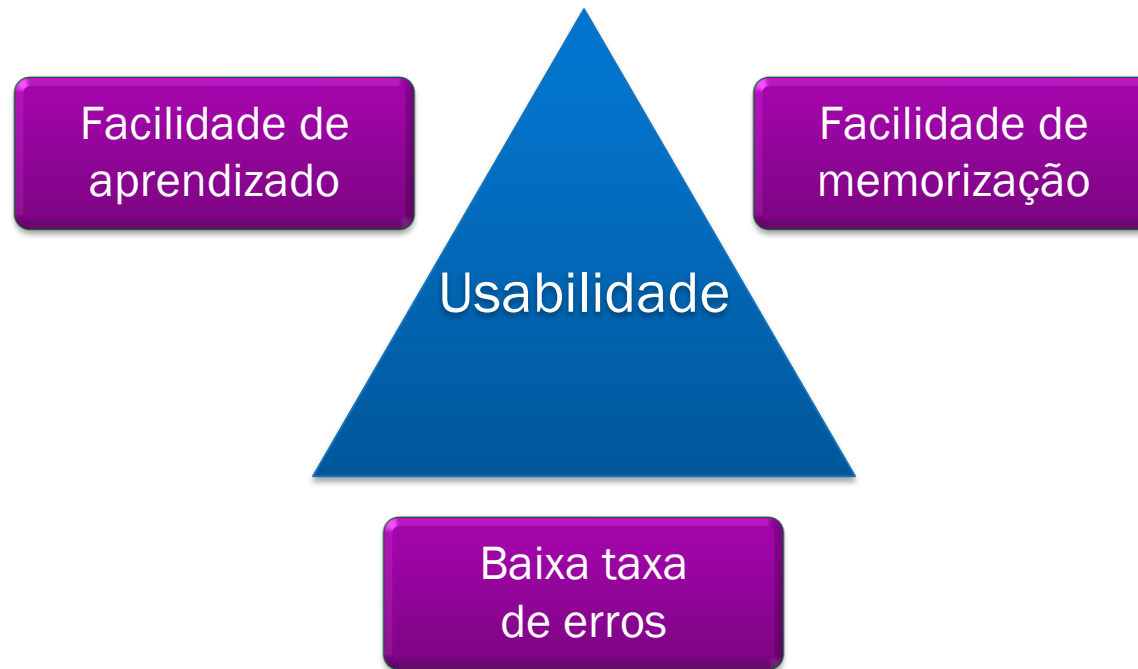

Design Centrado no Usuário

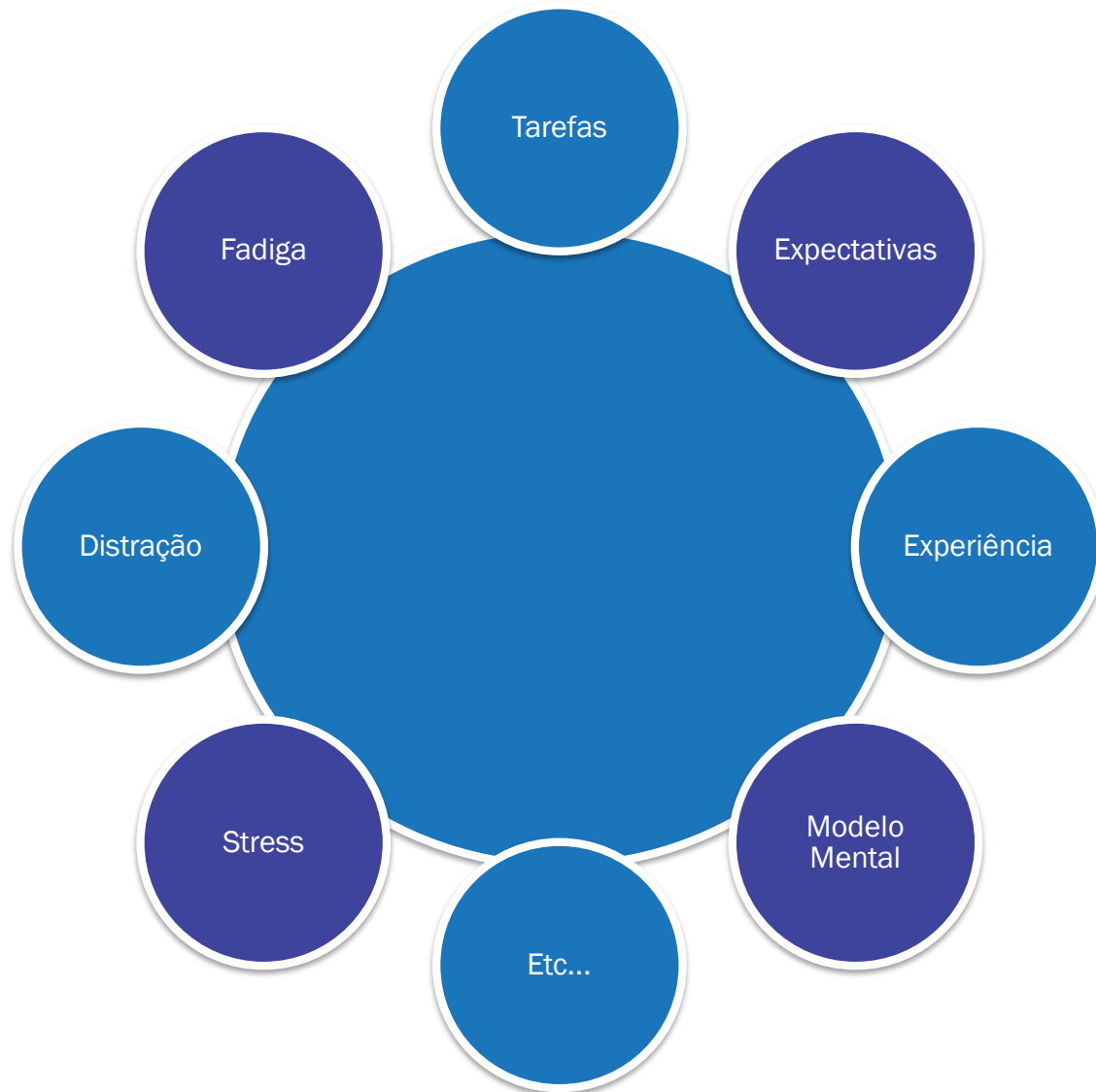

Acidente BP Texas (2005)



15 mortos
180 feridos



U. S. Chemical Safety and Hazard Investigation Board - <http://www.csb.gov/assets/1/19/CSBFinalReportBP.pdf>

Accidente BP Texas (2005)

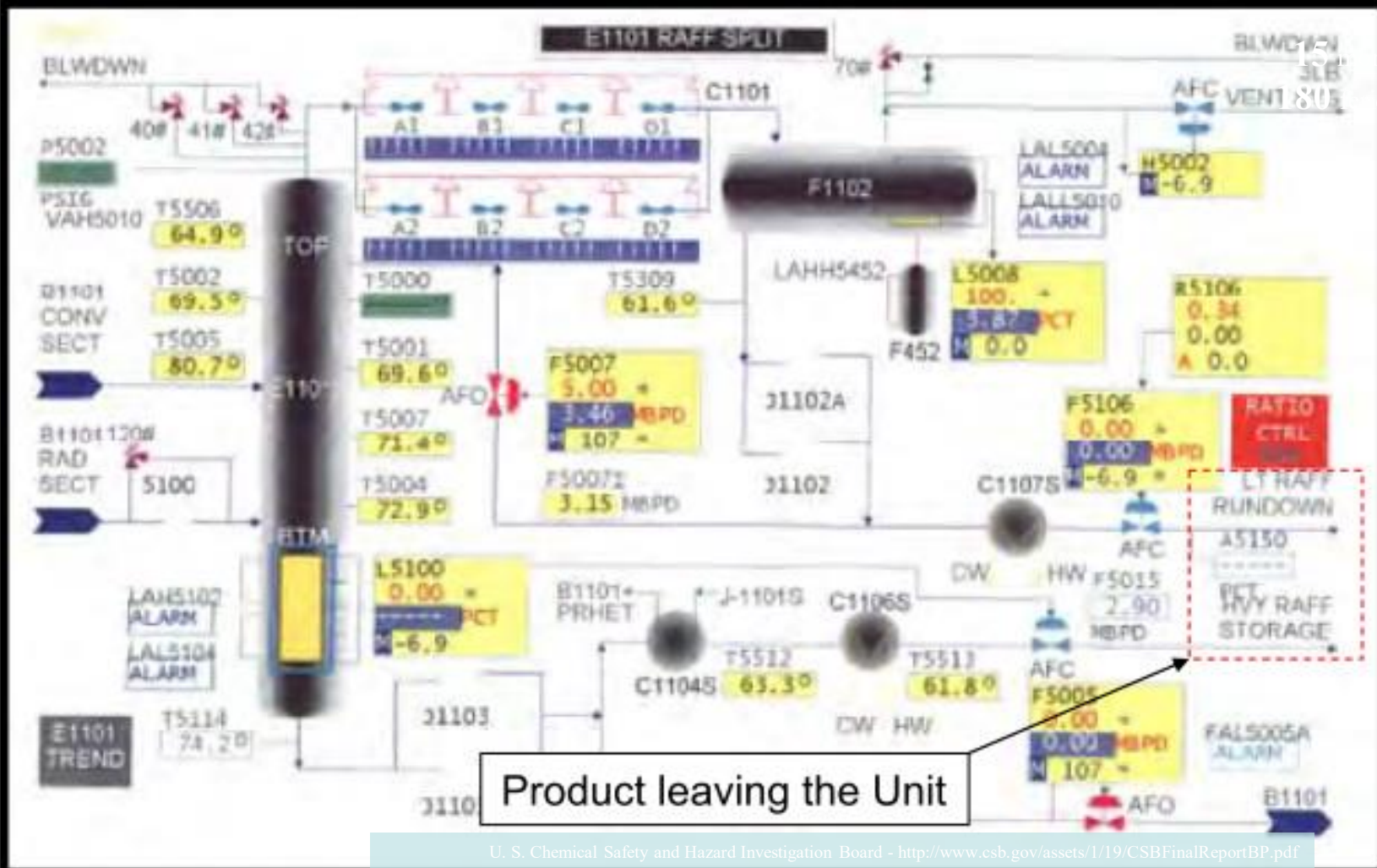

Accidente Indian Airlines (1990)



92 mortos
54 feridos



<http://www.airdisaster.com/photos/ia605/photo.shtml>

Acidente Indian Airlines (1990)



92 mortos
54 feridos

Antes do acidente

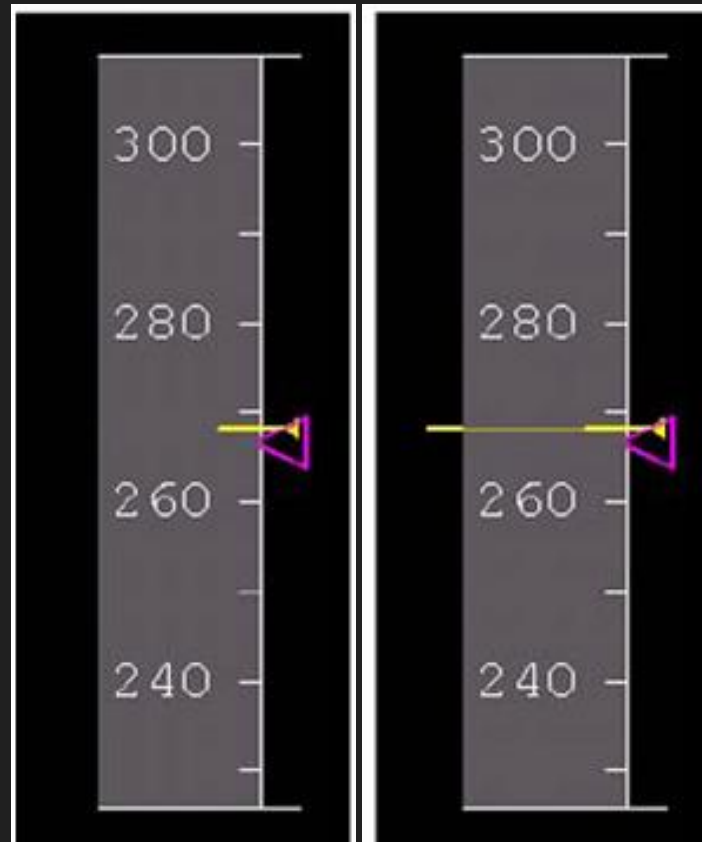

Melhoria implementada após o acidente

Consciência Situacional

Situational Awareness



Consciência Situacional é estar ciente do que se passa ao seu redor. É a perfeita sintonia entre a situação percebida e a situação real.

Consciência Situacional

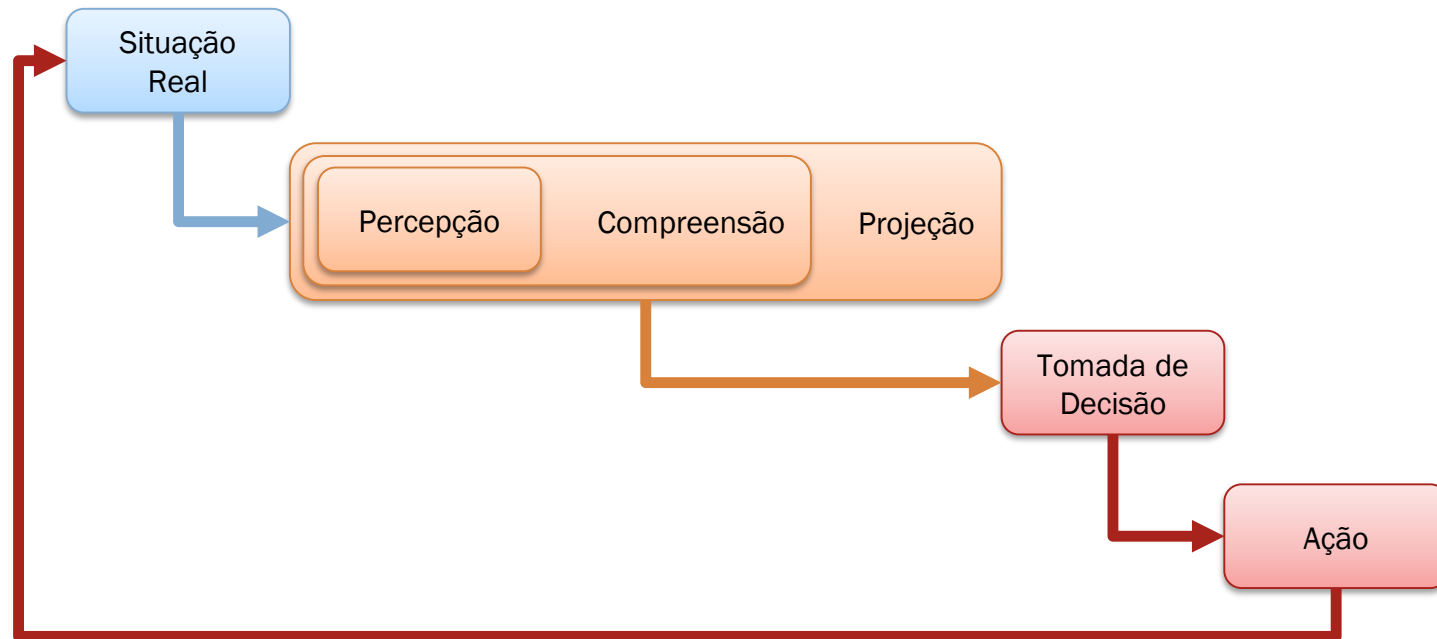

Modelo de Endsley para Consciência Situacional (1988)

Situational Awareness

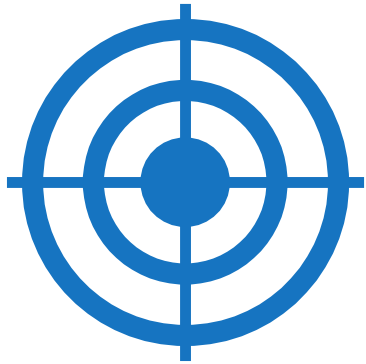

Objetivo desta metodologia:
**Aumentar a
Consciência Situacional
do Operador**

Situational Awareness

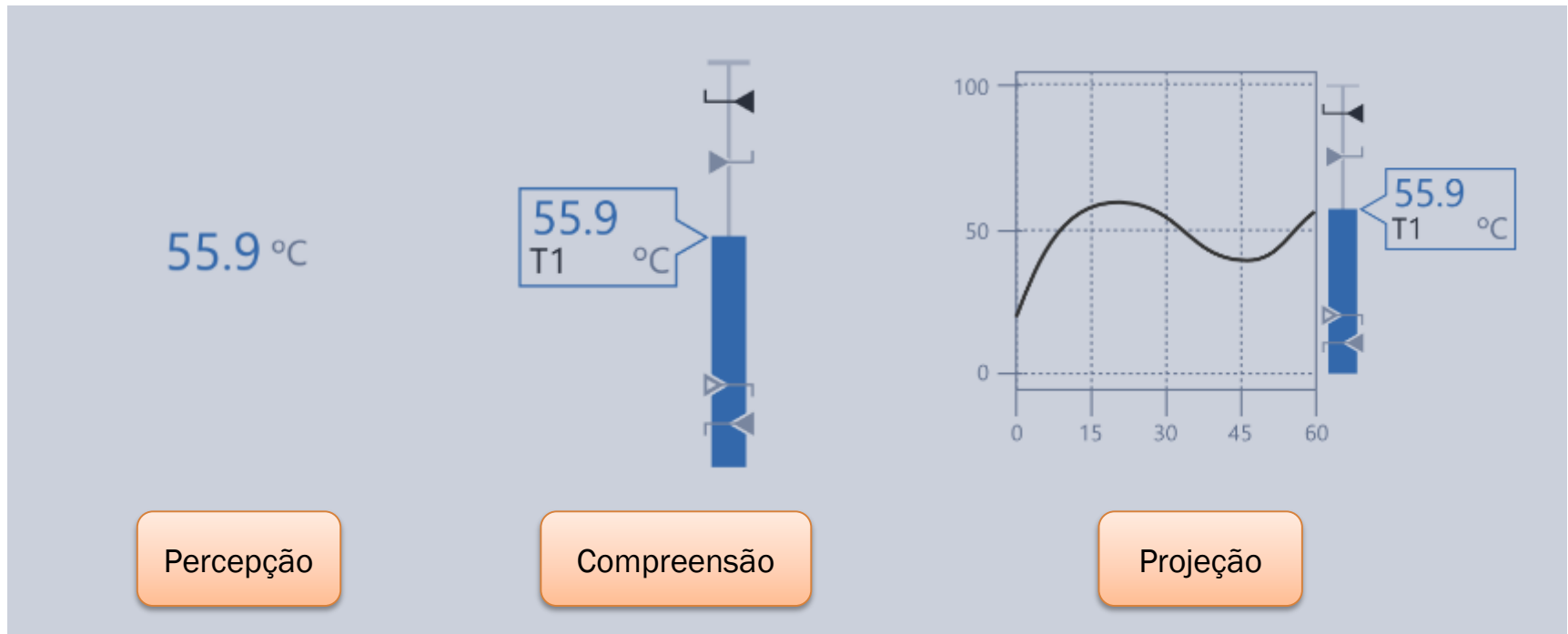

Acidente Kegworth Air (1989)



47 mortos
79 feridos



http://www.aaib.gov.uk/publications/formal_reports/4_1990_g_obme.cfm

Acidente Kegworth Air (1989)



Antes da modernização

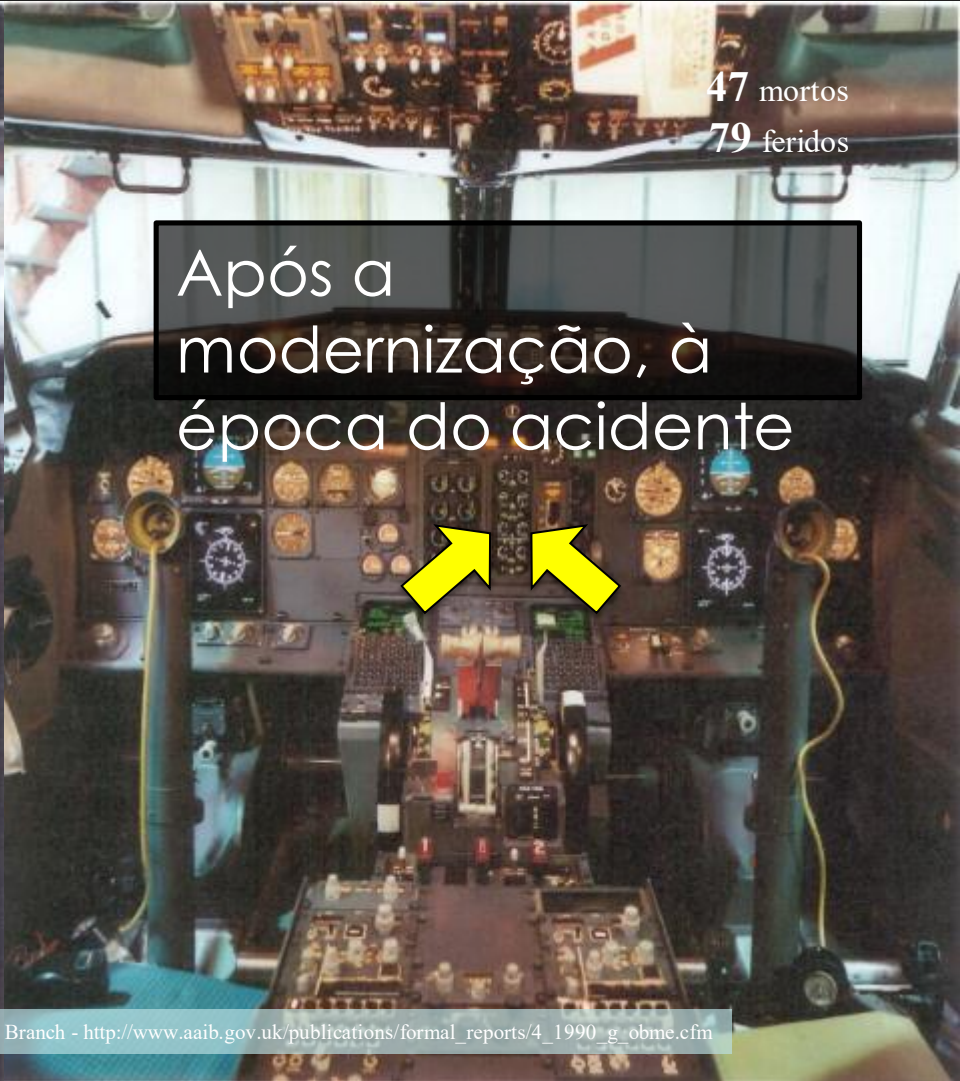

Após a modernização, à época do acidente

47 mortos
79 feridos



*Não vemos com nossos
olhos, e sim com o
cérebro.*

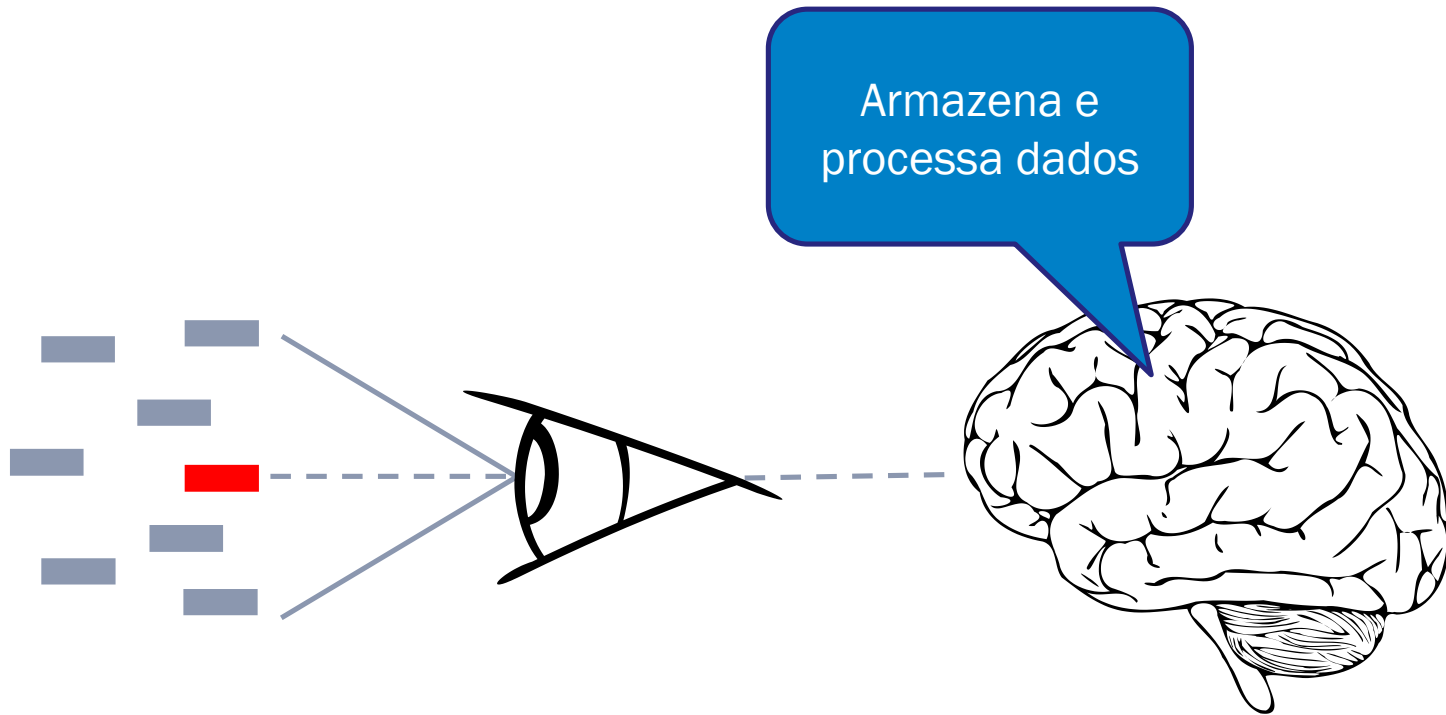

Cognição e interfaces

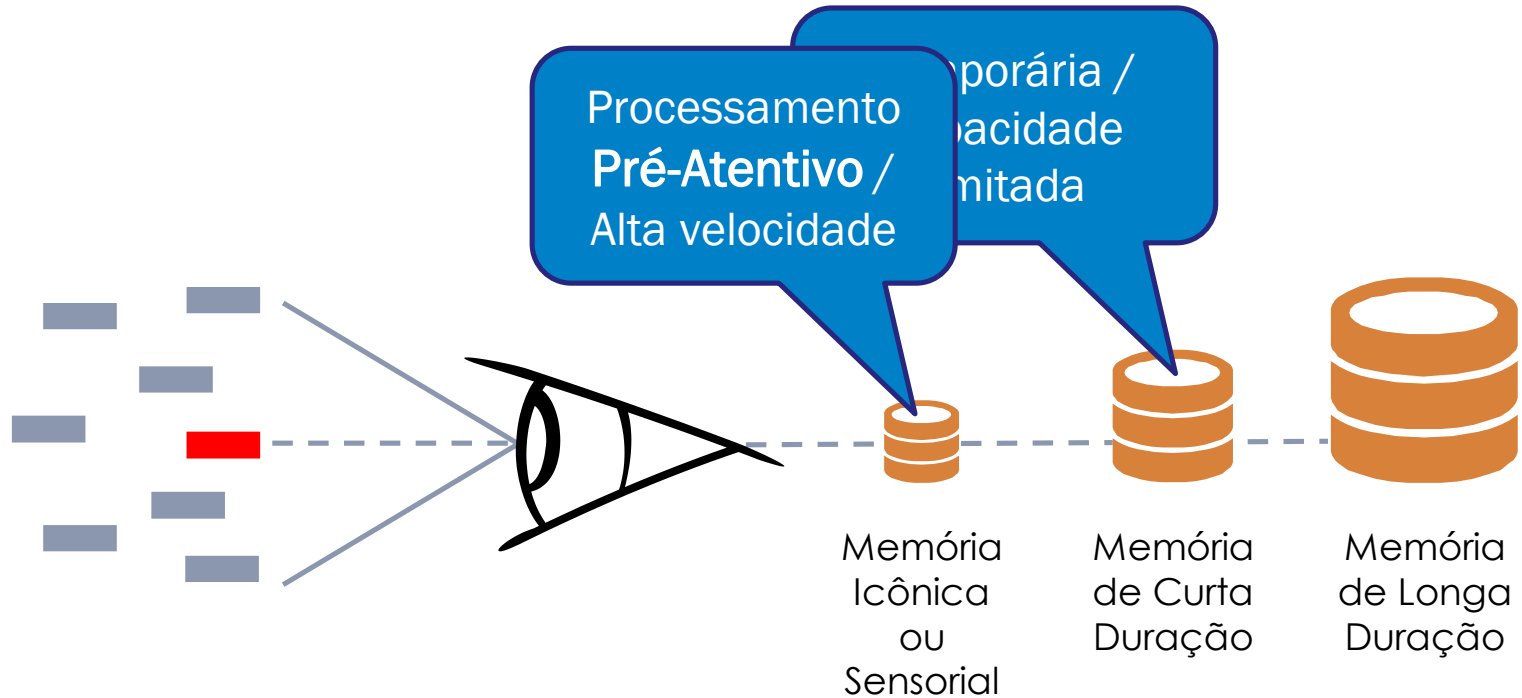

Quantos números “5” existem nas linhas abaixo?

294873198246182375976482916
461873192846758926437813747
164758293164973491643798132
467283916437982392415764973

Apresentação eficiente da informação



Mais fácil assim, não?

29487319824618237**5**976482916
4618731928467**5**8926437813747
1647**5**8293164973491643798132
46728391643798239241**5**764973

Cognição e interfaces

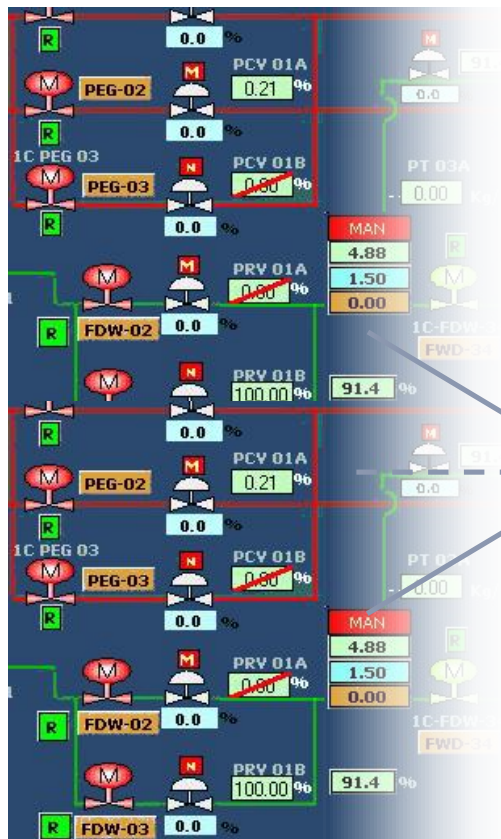

Excesso de estímulo visual gera PERDAS

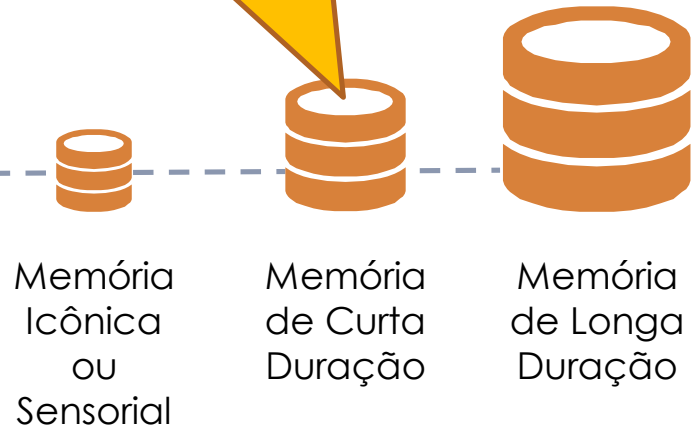

Cognição e interfaces

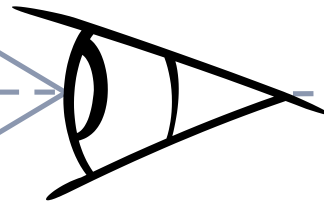
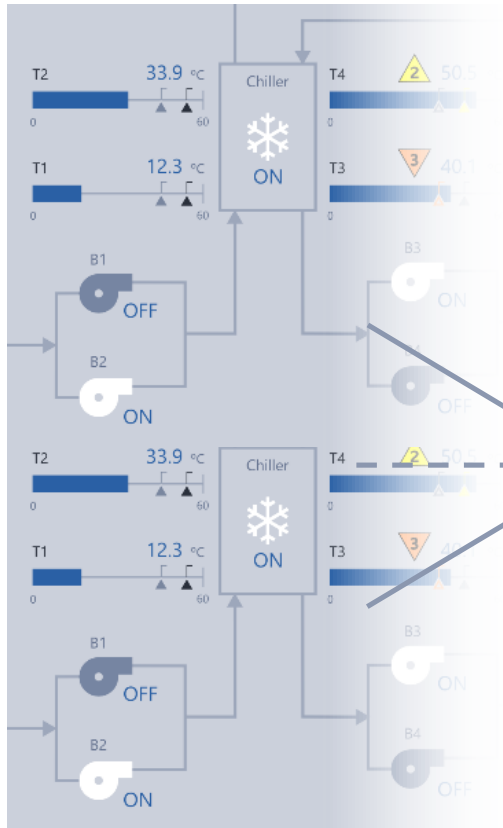

Design Pré-Atentivo
não sobrecarrega o
sistema cognitivo



Memória
Icônica
ou
Sensorial



Memória
de Curta
Duração



Memória
de Longa
Duração

Apresentação eficiente da informação



TE1	25.1 °C	TR1	16.0 °C	GD1	9.1 °C
TE2	22.3 °C	TR2	13.2 °C	GD2	9.1 °C
TE3	21.6 °C	TR3	12.6 °C	GD3	9.0 °C
TE4	22.4 °C	TR4	30.9 °C	GD4	-8.5 °C
TE5	22.3 °C	TR5	13.4 °C	GD5	8.9 °C
TE6	21.5 °C	TR6	12.5 °C	GD6	9.0 °C
TE7	26.9 °C	TR7	16.8 °C	GD7	10.1 °C

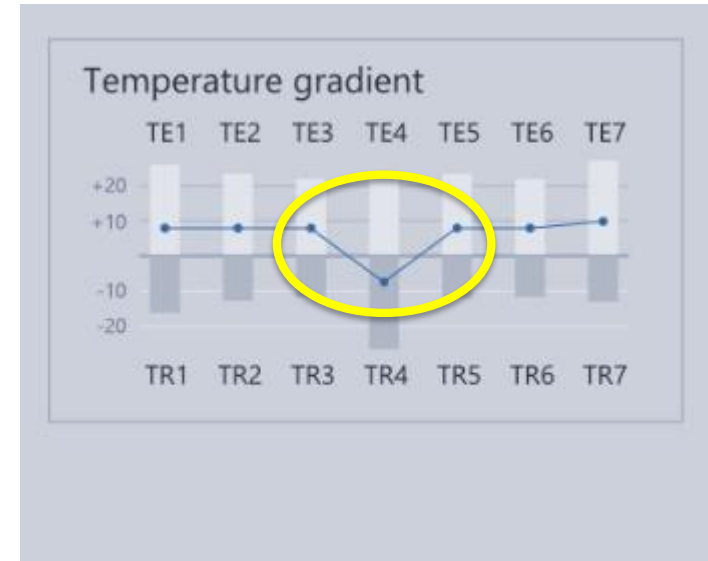

Muitas unidades de informação
+ Memória e Processamento

Poucas unidades de informação
- Memória e Processamento

Apresentação eficiente da informação



Cor



Acessibilidade



Posição



Forma



Movimento



Dados mais importantes devem se destacar dos demais.

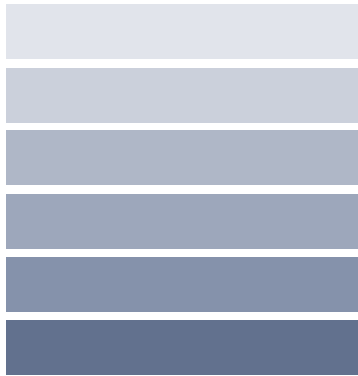

Cores para Uso Normal

Representação de objetos em geral e status.



Cores para Ênfase

Indicação de Alarmes, Falhas, Bloqueios, Inibições, SetPoints, Intertravamentos

elipse
software

Air-Conditioning Demo Screen

Normal

Cores para Ênfase

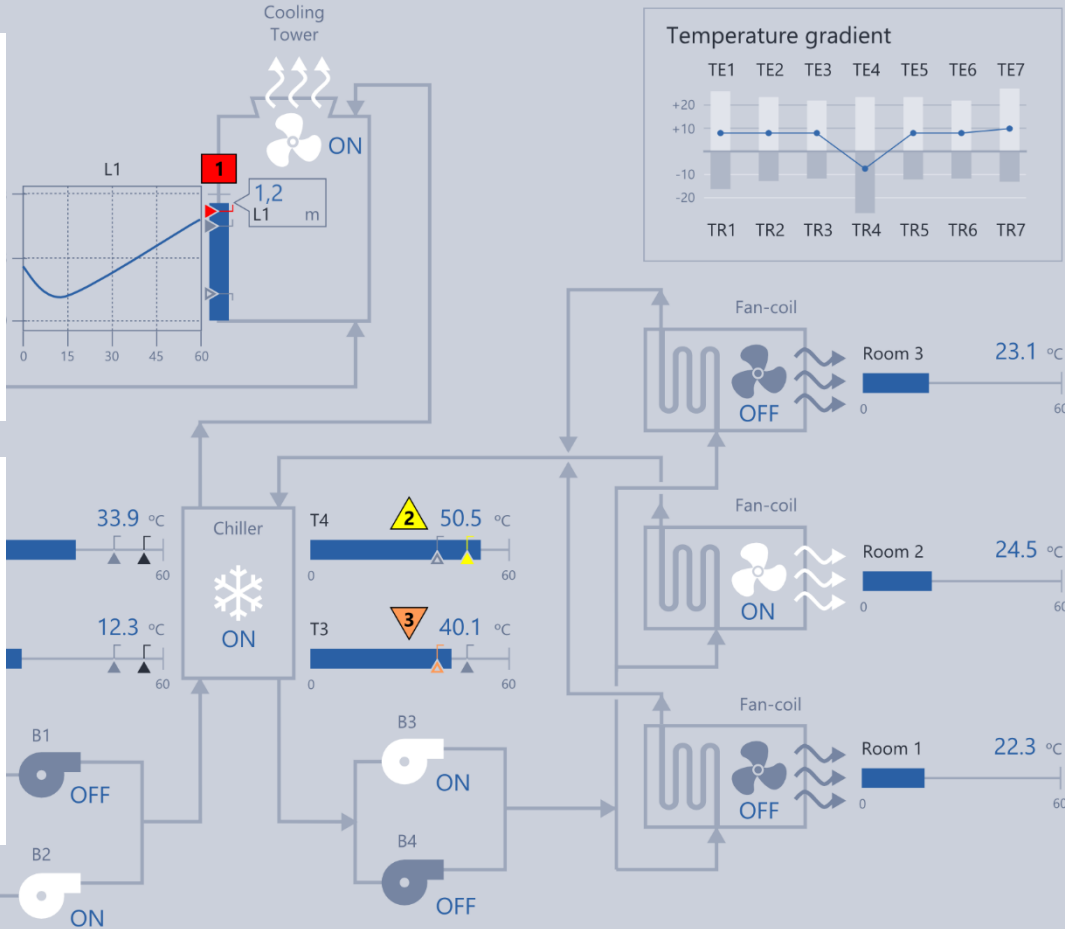

Cuidado com Gradientes de Cores!

Gradiente de cores no fundo e na tubulação

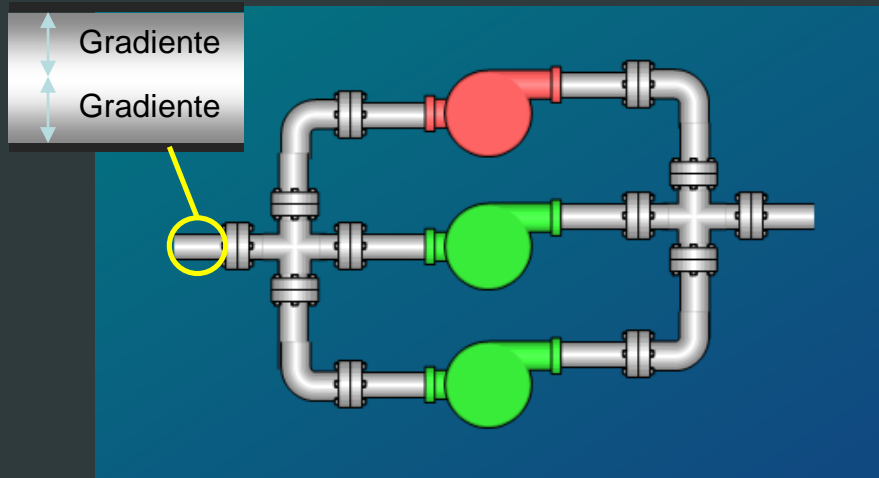

Excesso de pixels com função “decorativa”
(Non-Data Pixels)

Sem gradiente de cores

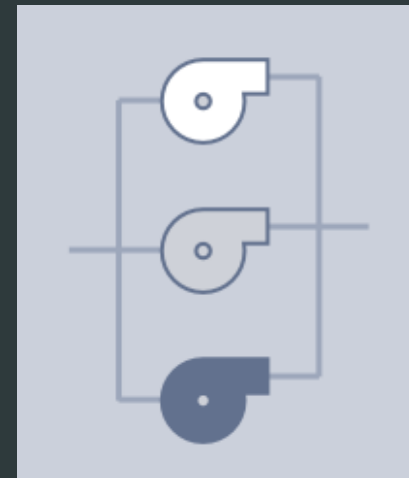

Destaque para pixels de dados
(Data Pixels)
Exclusão de pixels “decorativos”

Contexto afeta nossa percepção de cor

Representar “Quantidade” por comprimento de linha

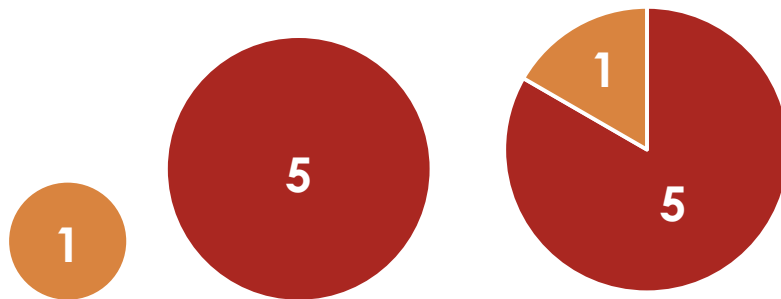

Ruim

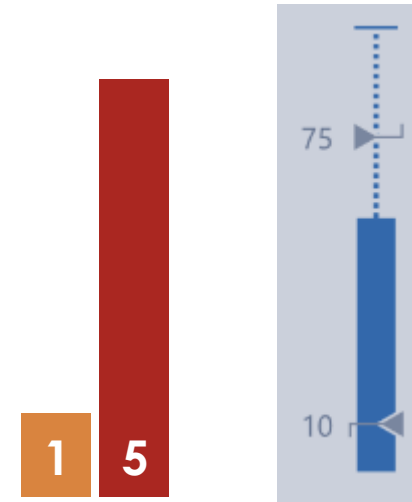

BOM

Representar “Hierarquia” por tamanho de objeto



Tela Temperaturas

Mancal da Turbina 1

Sensor 1 41.9 °C

Sensor 2 40.4 °C

Sensor 3 42.3 °C

Sensor 4 39.9 °C

Criar categorias de textos de acordo com a sua função.

Representar “Agrupamento” por contornos e preenchimentos ao redor dos objetos de um mesmo grupo

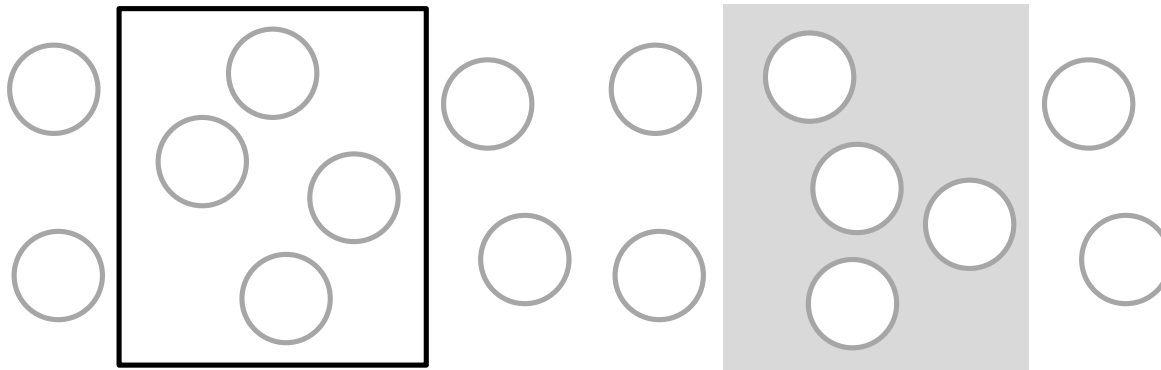

Representar “Agrupamento” por contornos e preenchimentos ao redor dos objetos de um mesmo grupo

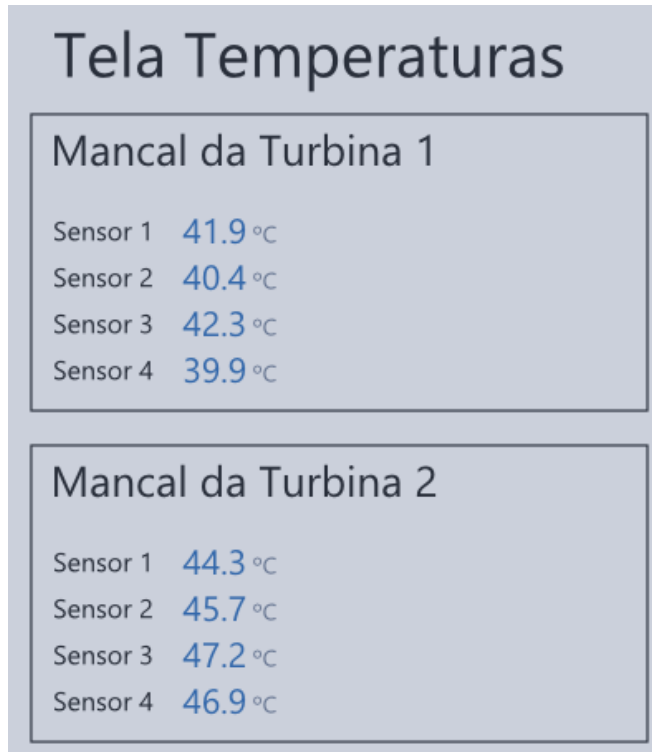

O Daltonismo é um distúrbio visual que impede a pessoa de diferenciar algumas cores:

- **Vermelho-Verde**: até 8% homens, 0.5% mulheres (populações com ascendência do norte europeu)
- **Azul-Amarelo**: 1 em cada 10.000 pessoas
- Acromatopsia completa: 1 em cada 30.000 pessoas

Mudar a FORMA dos objetos para indicar diferença de status, e não apenas a cor

COR

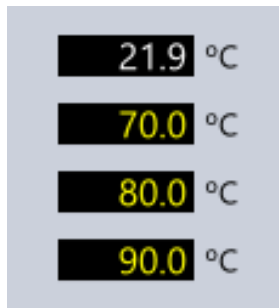

Tons de

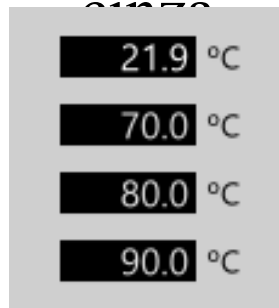

COR

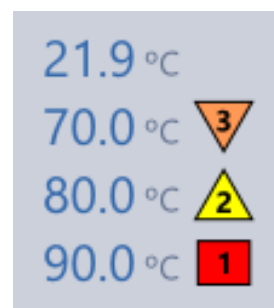





Tons de



Ruim

BOM

Mudar a FORMA dos objetos para indicar diferença de status, e não apenas a cor

	Severidade 1
	Severidade 2
	Severidade 3
	Severidade 4

Contrastes luminosos grandes são mais fáceis de identificar.

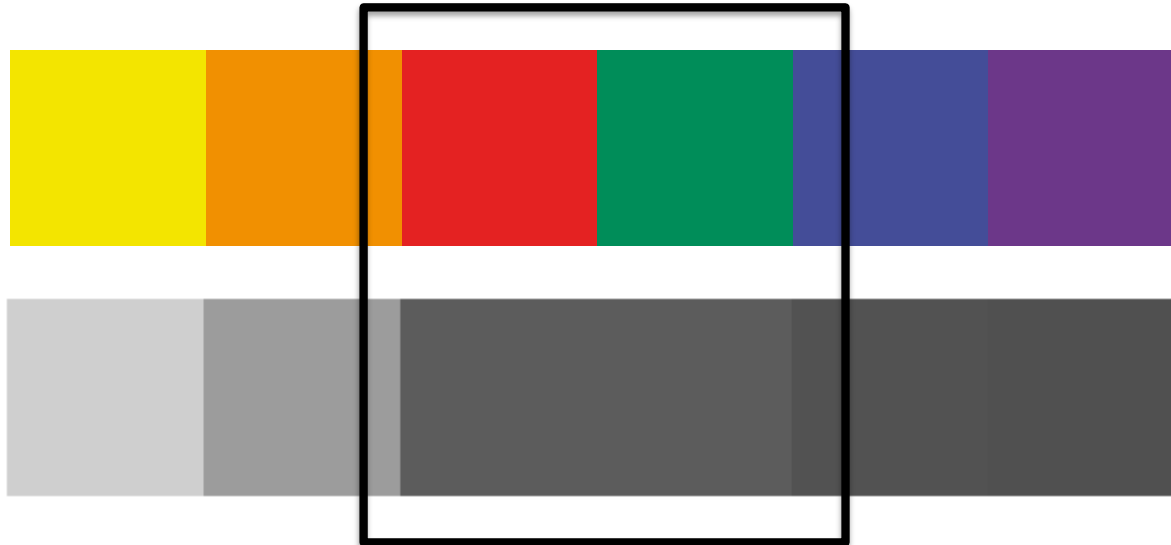

Vermelho-Verde

Alto contraste de tom
Baixo contraste luminoso

Contrastes luminosos grandes são mais fáceis de identificar.

COR

Tons de

COR

Tons de

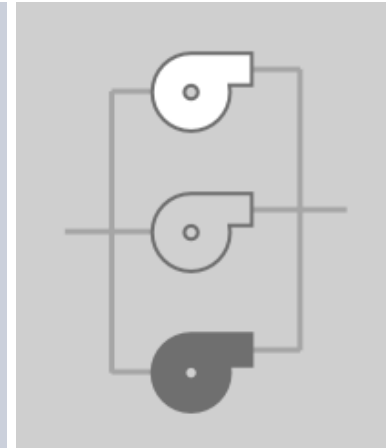
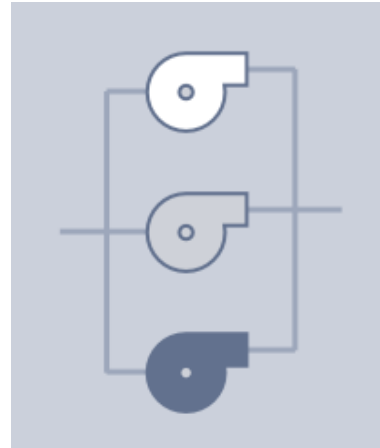
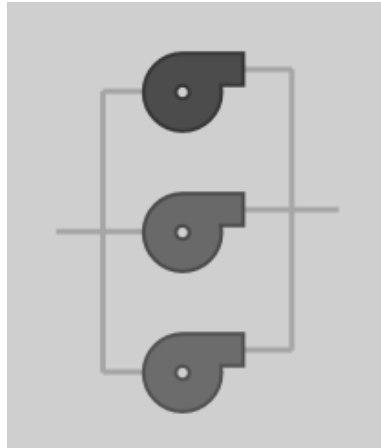
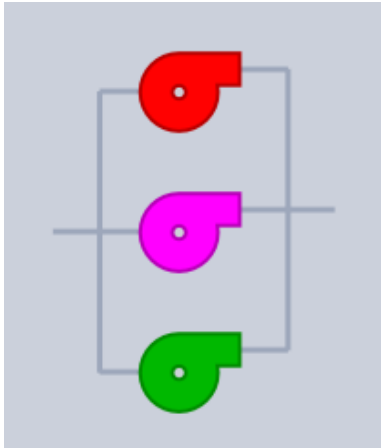

Ruim (Baixo Contraste)

BOM (Alto Contraste)

Contrastes luminosos grandes são mais fáceis de identificar.

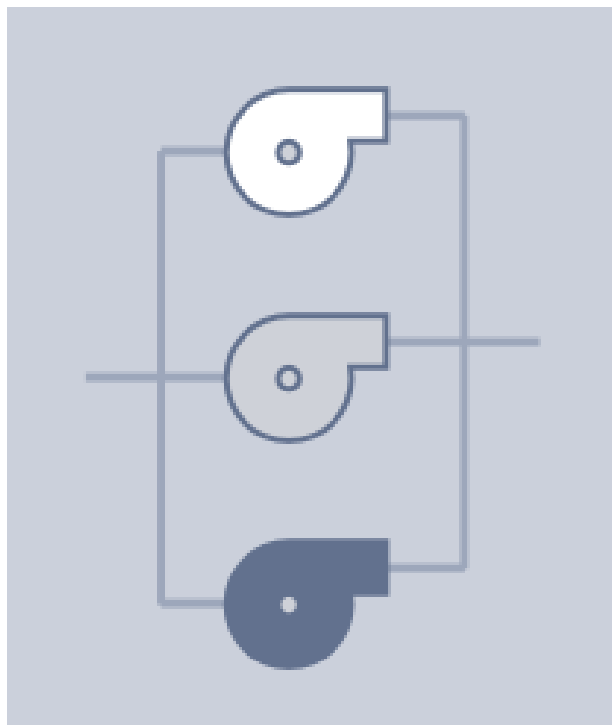

Mais claro que o
fundo:
DESLIGADO

Mesma cor que o fundo:
outro estado, p.e.
INVÁLIDO

Mais escuro que o
fundo:
LIGADO

Movimento é um poderoso atrativo para os olhos, muito usado como recurso de **entretenimento**.

Deve ser usado com critério:

- Pisca para alarmes não reconhecidos.
- Movimentação de objetos não é recomendada.

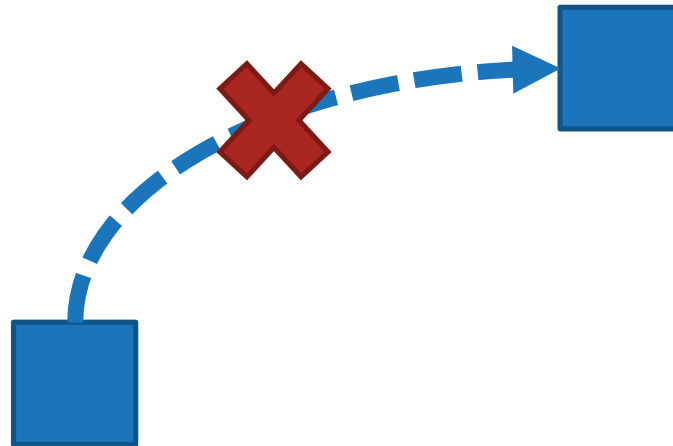

Dê preferência a um posicionamento plano.

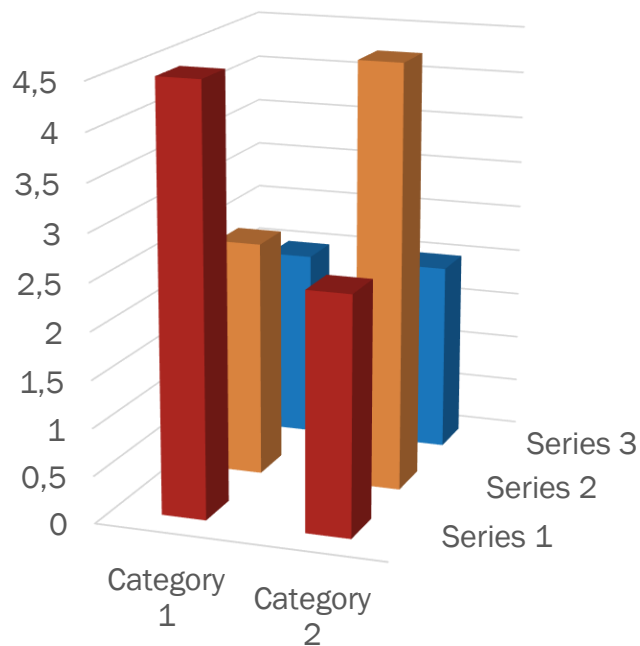

Ruim

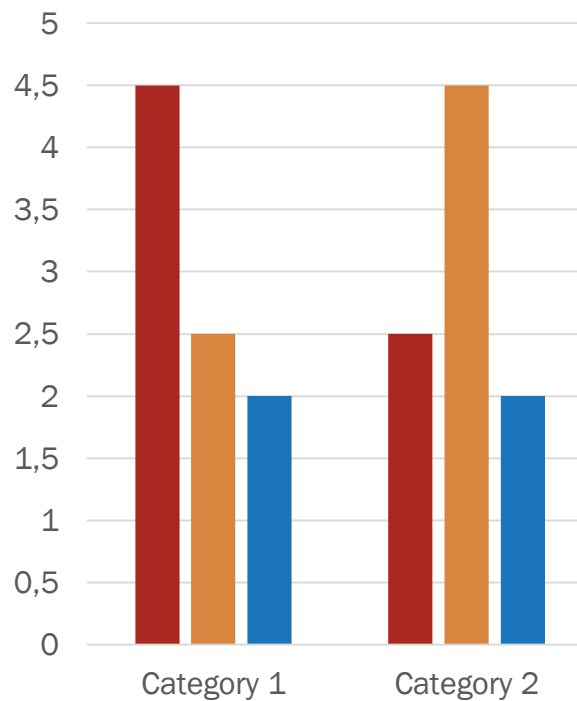

BOM

Dê preferência a um posicionamento plano.

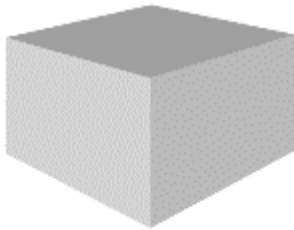

Ruim

BOM

Telas 3D são boa opção?

Desvantagens

- Percepção espacial limitada (*3D é um efeito visual ilusório, não é real*)
- Excesso de cores e detalhes visuais (*Sobrecarga cognitiva*)
- Empobrece a representação da informação (*Visibilidade, Legibilidade e Posição prejudicadas*)

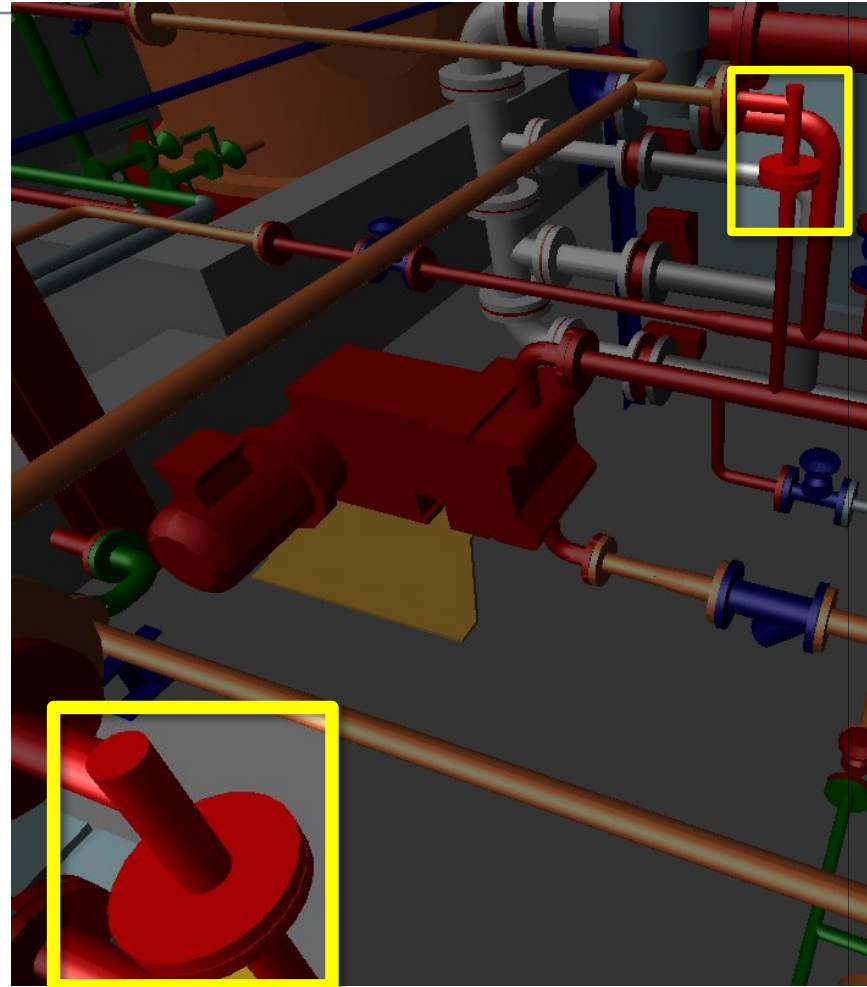

Telas 3D são boa opção?

Vantagens

- Grande apelo estético
- Favorece a visão geral em detrimento do detalhe
- Pode ser útil em:
 - Telas demonstrativas
 - Telas de navegação
 - Telas de visão geral, sem status nem controle

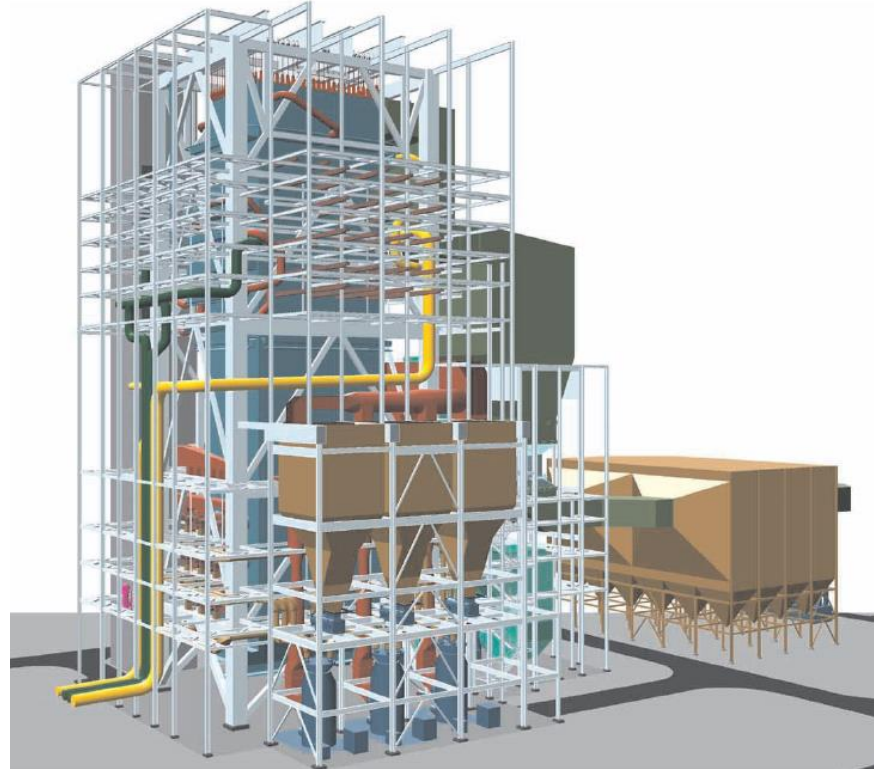

ETA - Visão Geral

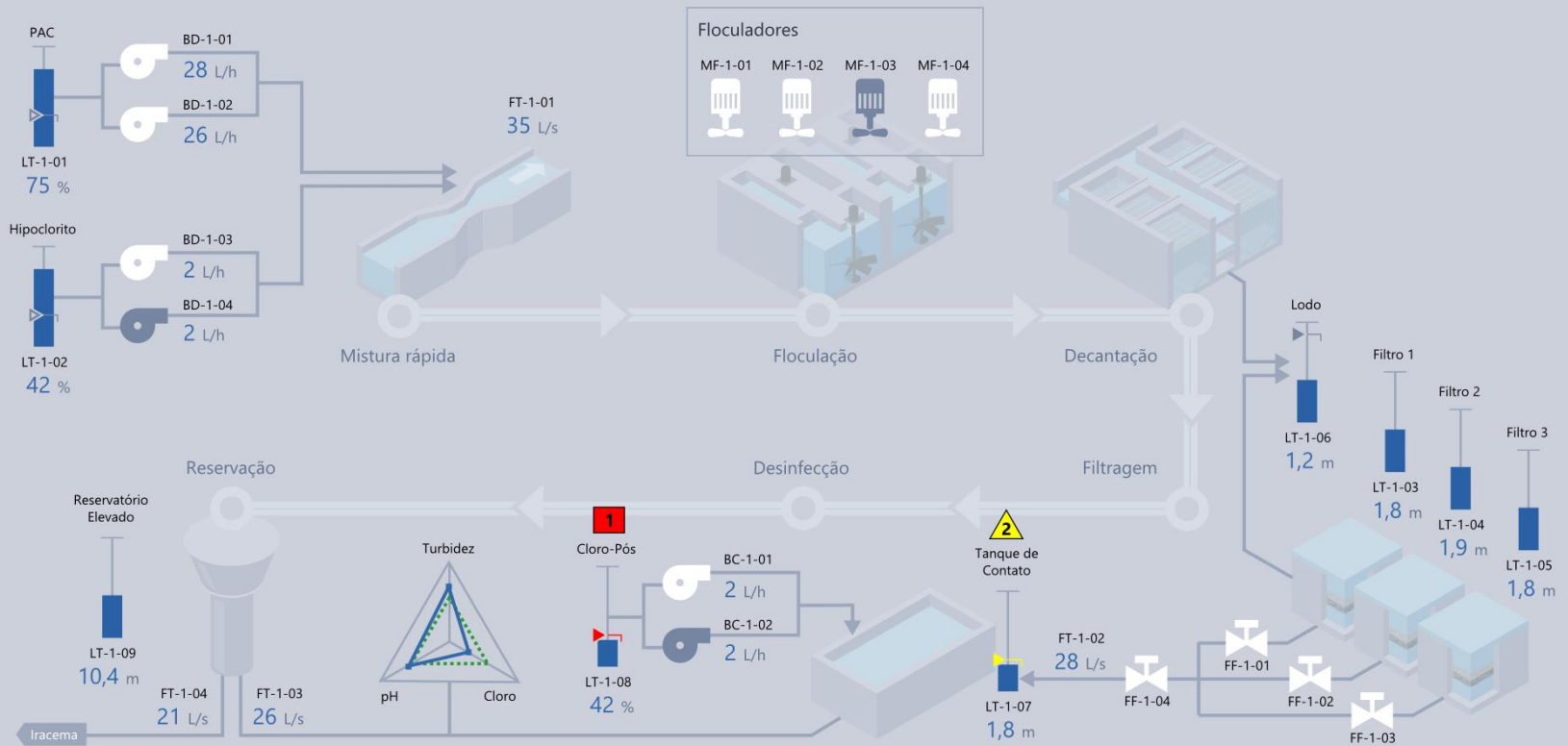

Alguns Desafios em que a Norma ISA-101 pode lhe Ajudar...



- Mapear as expectativas de todos os stakeholders e implementá-las da melhor forma possível
- Especificar e avaliar o desempenho do sistema IHM
- Criar diferentes níveis de visualização dos dados

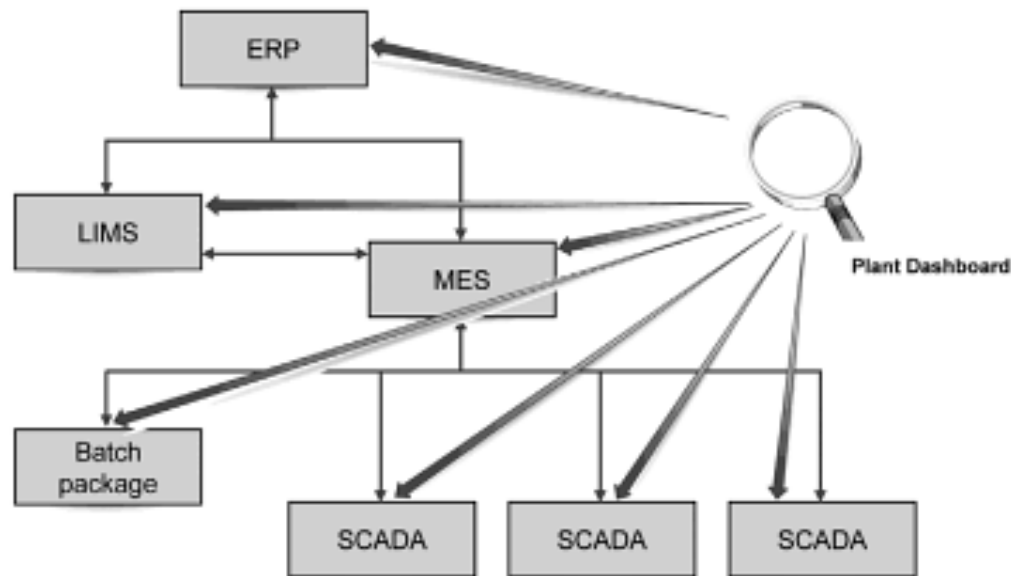

Alguns Desafios em que a Norma ISA-101 pode lhe Ajudar...



- Equalizar o nível de conhecimento de todos os usuários da IHM

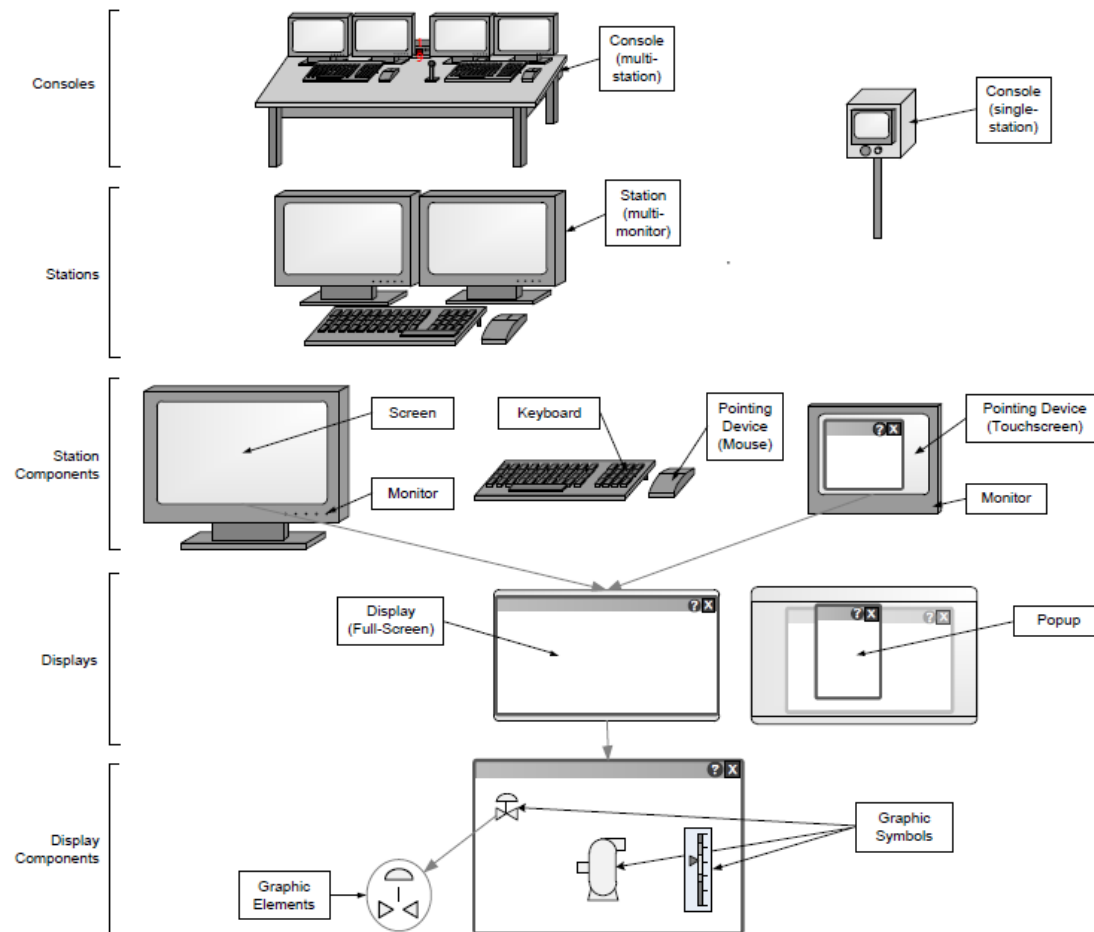

O que podemos encontrar por aí...

- Cores, Consistência, Redundância, Densidade, Animações, Criar Grupos de Dados...

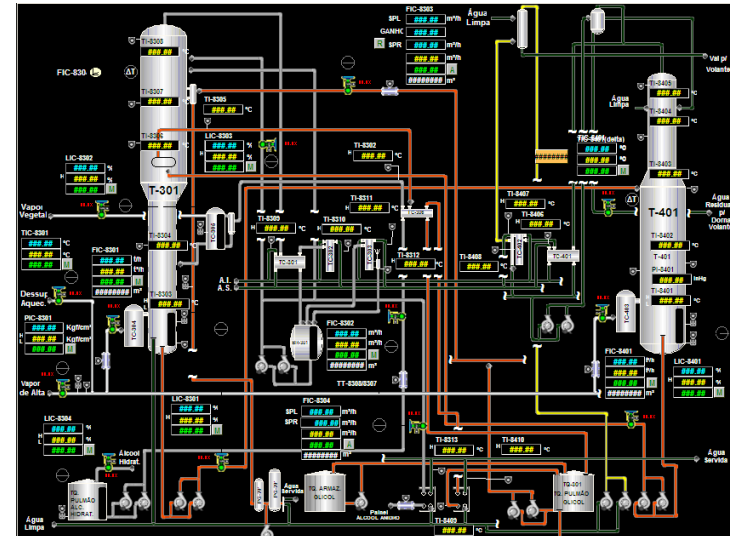
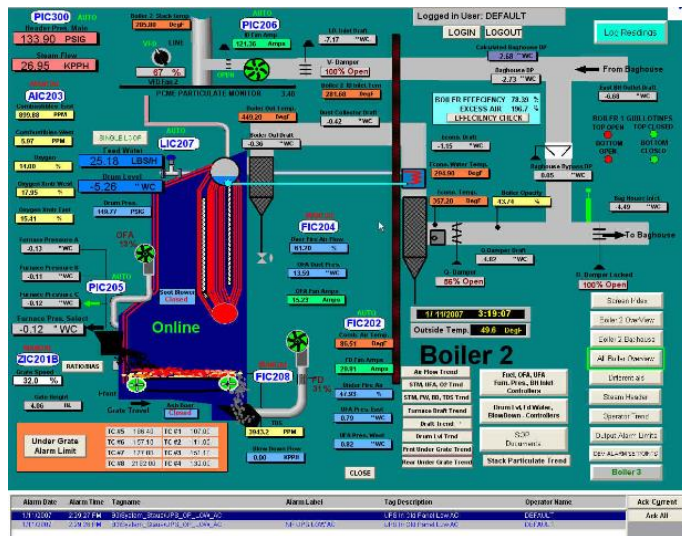
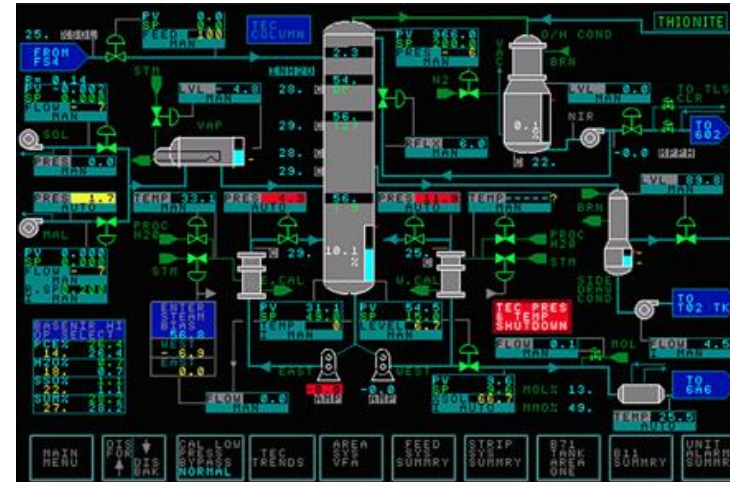
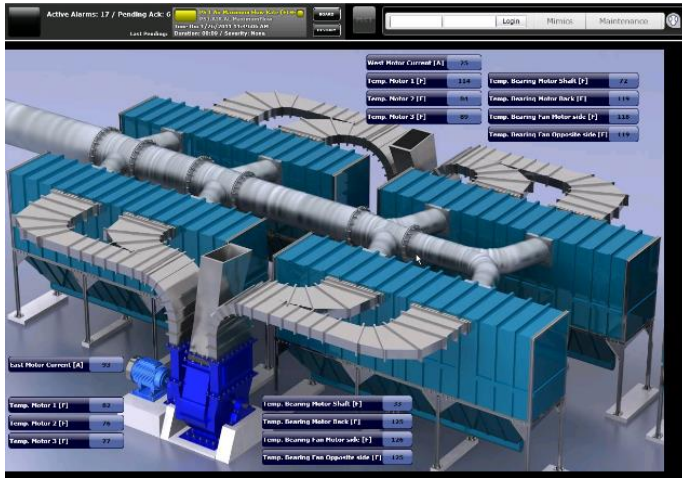

Alguns Conceitos Presentes na ISA-101 (Lifecycle)

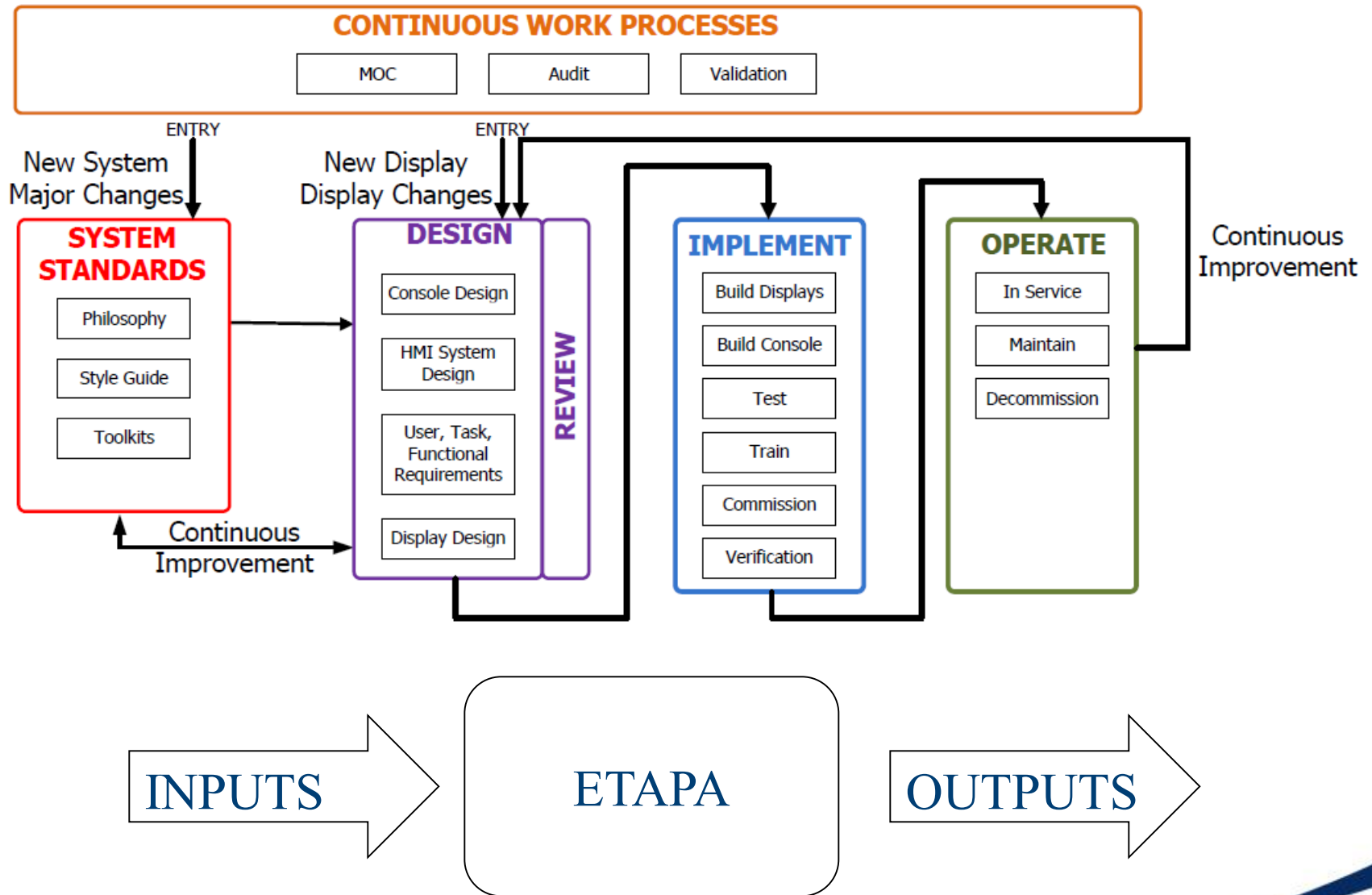

Alguns Conceitos Presentes na ISA-101 (Display Styles)



Type	Description	Examples	Sample																																																																																																																																				
List	Rows or lists of data, Text and numeric data may be intermingled with process equipment symbols	Tank strapping tables, safe operating limit tables, equipment lists	<table border="1"> <thead> <tr> <th rowspan="2">TANK HEIGHT WITH USABLE OIL CAPACITY IN CUBIC INCHES</th> <th colspan="6">MODEL NUMBER</th> </tr> <tr> <th>A-21</th> <th>A-22</th> <th>A-23</th> <th>A-24</th> <th>A-25</th> <th>A-26</th> </tr> </thead> <tbody> <tr> <td>1"</td> <td>5</td> <td>3</td> <td>12</td> <td>20</td> <td>28</td> <td>35</td> </tr> <tr> <td>2"</td> <td>12</td> <td>14</td> <td>24</td> <td>39</td> <td>48</td> <td>100</td> </tr> <tr> <td>3"</td> <td>15</td> <td>25</td> <td>37</td> <td>49</td> <td>54</td> <td>150</td> </tr> <tr> <td>4"</td> <td>19</td> <td>33</td> <td>50</td> <td>75</td> <td>112</td> <td>159</td> </tr> <tr> <td>5"</td> <td>24</td> <td>41</td> <td>62</td> <td>89</td> <td>140</td> <td>245</td> </tr> <tr> <td>6"</td> <td>29</td> <td>49</td> <td>75</td> <td>119</td> <td>165</td> <td>259</td> </tr> <tr> <td>7"</td> <td>34</td> <td>58</td> <td>87</td> <td>137</td> <td>197</td> <td>349</td> </tr> <tr> <td>8"</td> <td>39</td> <td>66</td> <td>100</td> <td>156</td> <td>231</td> <td>399</td> </tr> <tr> <td>9"</td> <td>44</td> <td>74</td> <td>112</td> <td>176</td> <td>255</td> <td>449</td> </tr> <tr> <td>10"</td> <td>48</td> <td>82</td> <td>128</td> <td>198</td> <td>281</td> <td>499</td> </tr> <tr> <td>11"</td> <td>53</td> <td>90</td> <td>137</td> <td>215</td> <td>305</td> <td>449</td> </tr> <tr> <td>12"</td> <td>58</td> <td>99</td> <td>149</td> <td>234</td> <td>337</td> <td>559</td> </tr> <tr> <td>13"</td> <td>63</td> <td>107</td> <td>162</td> <td>254</td> <td>365</td> <td>449</td> </tr> <tr> <td>14"</td> <td>68</td> <td>116</td> <td>174</td> <td>273</td> <td>393</td> <td>559</td> </tr> <tr> <td>15"</td> <td>73</td> <td>125</td> <td>187</td> <td>293</td> <td>421</td> <td>749</td> </tr> <tr> <td>16"</td> <td>78</td> <td>132</td> <td>199</td> <td>312</td> <td>449</td> <td>799</td> </tr> <tr> <td>17"</td> <td>83</td> <td>140</td> <td>212</td> <td>332</td> <td>477</td> <td>849</td> </tr> </tbody> </table>	TANK HEIGHT WITH USABLE OIL CAPACITY IN CUBIC INCHES	MODEL NUMBER						A-21	A-22	A-23	A-24	A-25	A-26	1"	5	3	12	20	28	35	2"	12	14	24	39	48	100	3"	15	25	37	49	54	150	4"	19	33	50	75	112	159	5"	24	41	62	89	140	245	6"	29	49	75	119	165	259	7"	34	58	87	137	197	349	8"	39	66	100	156	231	399	9"	44	74	112	176	255	449	10"	48	82	128	198	281	499	11"	53	90	137	215	305	449	12"	58	99	149	234	337	559	13"	63	107	162	254	365	449	14"	68	116	174	273	393	559	15"	73	125	187	293	421	749	16"	78	132	199	312	449	799	17"	83	140	212	332	477	849
TANK HEIGHT WITH USABLE OIL CAPACITY IN CUBIC INCHES	MODEL NUMBER																																																																																																																																						
	A-21	A-22	A-23	A-24	A-25	A-26																																																																																																																																	
1"	5	3	12	20	28	35																																																																																																																																	
2"	12	14	24	39	48	100																																																																																																																																	
3"	15	25	37	49	54	150																																																																																																																																	
4"	19	33	50	75	112	159																																																																																																																																	
5"	24	41	62	89	140	245																																																																																																																																	
6"	29	49	75	119	165	259																																																																																																																																	
7"	34	58	87	137	197	349																																																																																																																																	
8"	39	66	100	156	231	399																																																																																																																																	
9"	44	74	112	176	255	449																																																																																																																																	
10"	48	82	128	198	281	499																																																																																																																																	
11"	53	90	137	215	305	449																																																																																																																																	
12"	58	99	149	234	337	559																																																																																																																																	
13"	63	107	162	254	365	449																																																																																																																																	
14"	68	116	174	273	393	559																																																																																																																																	
15"	73	125	187	293	421	749																																																																																																																																	
16"	78	132	199	312	449	799																																																																																																																																	
17"	83	140	212	332	477	849																																																																																																																																	
Process	Graphic representation of process equipment, piping and instrumentation	PFD or P&ID style layouts																																																																																																																																					

Type	Description	Examples	Sample
Schematic overview	Informational overview of an operator's span of control. The types of controls and indicators needed will depend on the functional requirements.	Process area, utilities or transport overviews	
Functional overview (Dashboard)	Representation of functional relationship of data	Data types as required (e.g., key performance indicators)	
Topology (location)	Representation of logical layout of a system	System network Electrical system one-line Fire detection status display	
Graph	Chart based representation of real time or historical data	Real time or historical trends Statistical quality control or statistical process control charts	
Group	Task based collection of point display faceplates	Multi-unit boiler control valves Distillation column flow control valves	

Alguns Conceitos Presentes na ISA-101 (Display Styles)



Type	Description	Examples	Sample
Logic monitor	Display representing logical relationships between system functions	Boolean / Logic diagrams, function block diagrams, ladder logic diagrams, sequence diagrams	
Procedural	Display of procedural control logic	Sequential function chart diagrams	<p>Hazardous Liquid Trip Check</p> <p>Step 1: Select item to test. <input type="button" value="Select"/> <input type="button" value="▼"/></p> <p>Step 2: Verify trip occurred correctly: Controller and block valves closed: Operator: <input type="checkbox"/> Check for electrocutions. Inst. Tech: <input type="checkbox"/> Check for electrocutions.</p> <p>Step 3: Program waits for Historian to record trip.</p> <p>Step 4: Program returns test value to field reading.</p> <p>Step 5: Return Boiler to Normal Operations.</p>
Video	Displays of live or recorded video	Process video monitoring Security CCTV	
Health/Diagnostic	Display of status of certain infrastructure components of the HMI and control system.	Network health display	
Alarm list	Display a list of status information	Alarm summary display Shelved alarm list Out of service alarm list Message list Lightbox	

Alguns Conceitos Presentes na ISA-101 (Hierarchy & Navigation)

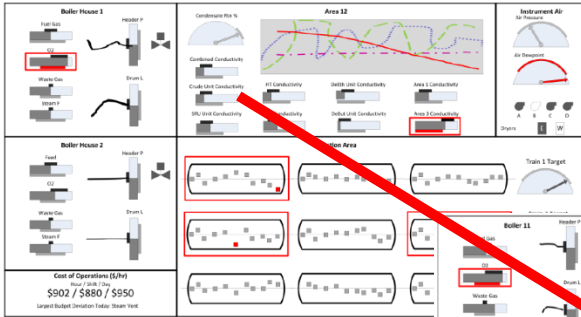

Nível 1



Nível 2

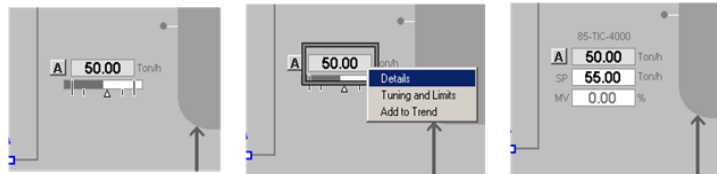

Nível 3

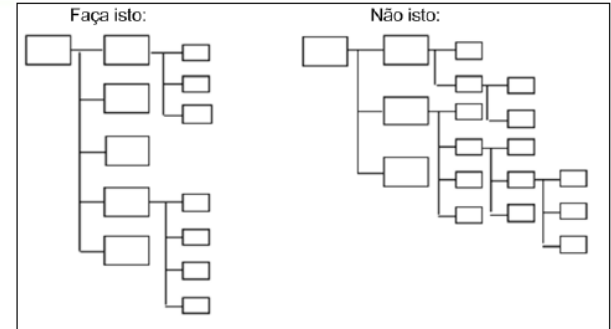
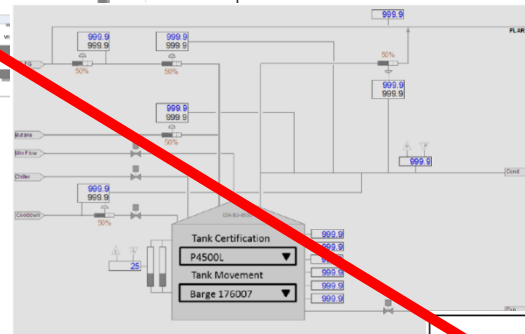

- Nível de detalhes aumenta de acordo com a navegação do Operador (Drill-Down)

Hazardous Liquid Trip Check

Step 1: Select item to test. TIC8700

Step 2: Verify trip occurred correctly:

- TIC8700 > Limit 986
- Current Reading: 987, XY8700 = CLOSED
- Controller and block valves closed:

Operator : John Smith, electronically signed.
Inst. Tech: Jane Doe, electronically signed.

Step 3: Program waits for Historian to record trip.

- Confirmation TIC8700 in historian 987.

Step 4: Program returns test value to field reading.

- PV Reading from Field

Step 5: OK to Return Boiler to Normal Operations.

Nível 4

Alguns Conceitos Presentes na ISA-101 (User Interaction)



- Métodos de prevenção de erros
- Consistência
- Representação Numérica
- Textos
- Comandos
- Botões
- Faceplate
- Cores
- Task Analysis

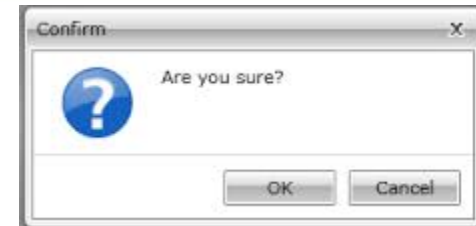

Engineering range	Decimal formatting
100 - 9999.9	XXXX
10 - 99.99	XX.X
1 - 9.999	X.XX
0 - 0.9999	X.XXX

The current font size is: 5pt
 The current font size is: 8pt
 The current font size is: 9pt
 The current font size is: 10pt
 The current font size is: 10.95pt
 The current font size is: 12pt
 The current font size is: 14.4pt
 The current font size is: 17.28pt
 The current font size is: 20.74pt
 The current font size is: 24.88pt

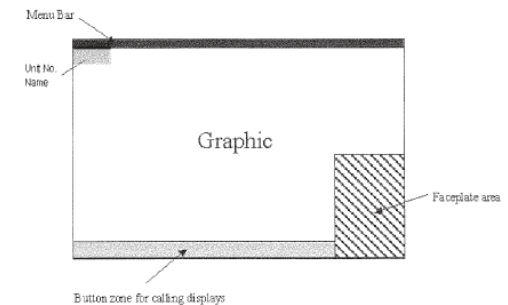
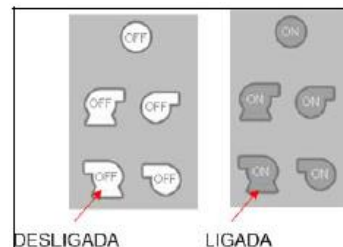
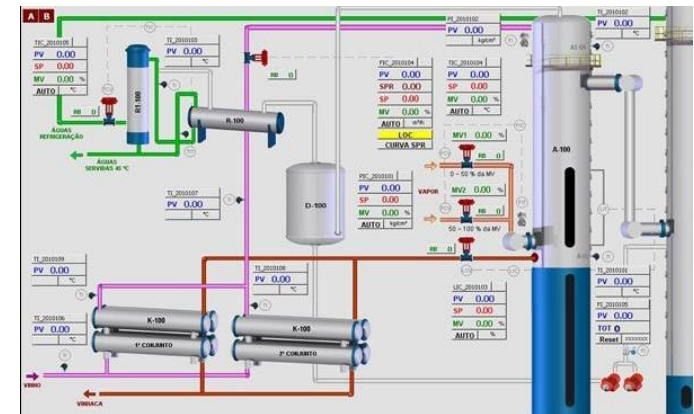

Fonte: EEMUA-201

Alguns Conceitos Presentes na ISA-101 (Performance)



- Tempo e esforço para acesso a tela da IHM
- Call up time: Atualização de todos os objetos e informações
- Display Refresh Rate: Intervalo entre as atualizações das informações
- Write Time: Tempo entre o valor ser alterado em tela e o controlador receber o valor
- Write Refresh Time: Tempo entre a ação do operador através da IHM e a resposta (*feedback*)



Metric	Display type	Maximum access times
Access to alarm displays	Alarm summary	1 sec
	Alarm lists such as suppressed alarms	5 secs
Navigation (Note 1)	Critical displays	1-2 clicks
	Non-critical displays	3 clicks
	Alarm summary	1 click
	System diagnostics	1-2 clicks
System state changes (Note 2)	Switching operators	5 secs
	Language change	5 secs

ISA-101 Example

Alguns Conceitos Presentes na ISA-101 (Training)



- Eventualmente requer o desenvolvimento de material dedicado (além dos Standards indicados no Lifecycle)
- Uso eficiente da IHM promove retornos financeiros
- Os objetos e interações não necessitam ser descobertos!
- Cada audiência com o seu treinamento personalizado

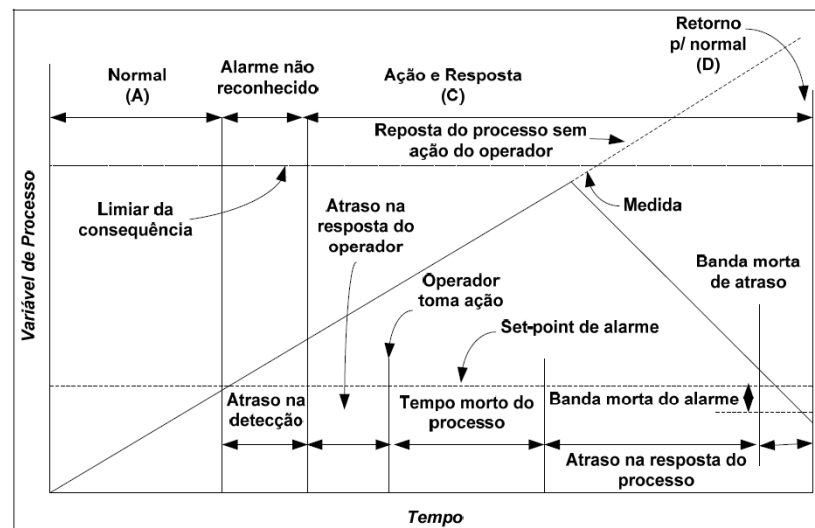

Como implementar a norma em seu processo industrial?



- Desenvolver sua fundamentação (Standards) seguindo as melhores práticas e aplicar as práticas de gestão recomendadas
- Algumas soluções de mercado já possuem em sua biblioteca (Toolkits) modelos e símbolos que atendem aos requerimentos desta e de outras normas da ISA
- Dar a importância requerida a IHM e transmiti-la para os demais stakeholders do sistema
- A IHM é um sistema! (diversos elementos que interagem com objetivo único)

Algumas fontes de informações que possam complementar...



Setting the Standard for Automation™



Introdução à Norma ISA-101: Interfaces Homem-Máquina

Standards
Certification
Education & Training
Publishing
Conferences & Exhibits

ISA Distrito 4 - Grupo Standards